

Medicine Devices



USER MANUAL ***MDC 4000vet***

MDC 4000vet

Semi-automated veterinary hematology analyzer for blood count

Operator manual 1.0
February 2005

Manufacturer:

Medicine Devices
AL Systeme
Unterer Dammweg 12
76149 Karlsruhe / Germany

PHONE: + 49 / (0) 721 / 97893 - 0
FAX: + 49 / (0) 721 / 97893 - 30

E-MAIL: alsysteme@aol.com
URL: www.medicinedevices.com

Disclaimer:

The information contained in this document has been carefully examined and is believed to be entirely accurate. However, MEDICINE DEVICES assumes no responsibility for errors or omissions. Users are fully responsible for their own applications at all times and should thoroughly verify all operations before committing the product to service. MEDICINE DEVICES reserves the right to make changes in this manual without prior notification in accordance with MEDICINE DEVICES' policy of product support and improvement.

1 INTRODUCTION

Hematology deals with the study of blood diseases and diseases of the blood-building organs. Because of the sensitivity of blood, a fairly exact diagnosis of different pathological conditions is possible.

Blood is the most important transporting organ of the body. Components that are carried by the blood, are either dissolved in the blood plasma -the serum-, or are carried by the blood corpuscles.

Electrolytes and hormones belong to the first, an example for the latter is oxygen, which is carried by the erythrocytes. Certain pathological conditions are reflected in the change of the amount or quality of the blood corpuscles, for example: volume or content.

The **Hematology-Veterinary System**, which is shown in the diagram, serves to establish what is called the small blood picture. In addition to this, information on distribution as well as measuring and calculated parameters are given.

As a result of automation the processing of samples is made very easy. With the built-in analyzer the size of the particles can be measured and platelets can be determined simultaneously with the RBC measurement.

Please note however that blood cells are particles of the same size as for example dust and other pollution. Blood cells react with great sensitivity to changes in their physical surroundings.

Therefore, the exactness of your measuring results depends not only on the system itself, but also to a large extent on how the system is handled, on how the blood is processed and on the quality of the solutions that are used. Of course, the handling of the system will affect the total result most, while good results will in turn affect your satisfaction with the instrument. The following chapters want to help you with the proper handling of the instrument.

1.1 GENERAL

As the system has only a limited data-output the display uses a number of common international abbreviations of parameters.

Abbreviations and their meanings:

RBC	-Amount of Red Blood Cells (Erythrocytes)
HCT	-Hematocrit (packed cell volume in %)
MCV	-Mean Corpuscular Volume (average Cell Size, Erythrocytes)
WBC	-Amount of White Blood Cells (Leukocytes)
LYM	- Amount of White Blood Cells (Lymphocytes)
MID	- Amount of White Blood Cells (Cells between LYM and GRAN)
GRAN	- Amount of White Blood Cells (Granulocytes)
THR/PLT	-Amount of Thrombocytes (Blood Platelets)
MPV	-Mean Platelet Volume (average Platelet Size)
PCT	-Platelet hematocrit (packed Cell Volume in %)
HGB	-Hemoglobin Concentration
MCH	-Mean Corpuscular Hemoglobin (average HGB weight/cell)
MCHC	-Mean Corpuscular Hemoglobin Concentration (Average hemoglobin concentration in %)
RCDW	-Distribution Control sector between RBC and THR-Population in %
LCDW	-Distribution Control sector of THR towards Electronic Noise in %

1.2 NORMAL VALUES FOR HUMAN

Parameter	Unit	Normal Range
RBC	10^{12} blood c./l	4,5 - 5,5 masc. 4,0 - 5,0 fem.
HCT	%	42 - 50 masc. 37 - 43 fem.
MCV	fl $1 \cdot 10^{-15}$	76 - 96
THR/PLT	10^9 blood c./l	150 - 400
MPV	fl $1 \cdot 10^{-15}$	7.2 - 11.1
PCT	%	3 - 8
WBC	10^9 blood c./l	4,0 - 9,0
LYM	10^9 blood c./l	1,0 - 4,0
MID	10^9 blood c./l	0,1 - 0,8
GRAN	10^9 blood c./l	2,6 - 9,2
LYM	%	25 - 30
MID	%	2 - 8
GRAN	%	60 - 70
HGB	g/l	140 - 170 masc. 120 - 150 fem.
MCH	pg $g \cdot 10^{-12}$	27 - 32
MCHC	g/l	320 - 360
LCDW	%	0 - 35
RCDW	%	0 - 15

1.3 NORMAL VALUES FOR ANIMAL

Animal	WBC x10 ³ /μl	RBC x10 ⁶ /μl	HGB g/dl	HCT %	MCV fl	PLT x10 ³ /μl,
Hamster	4,5 - 8,4	6,5 - 8,2	14,1 - 17,6	42 - 50	60 - 67	250 - 572
Dog	9,8 - 28,6	5,7 - 9,5	13,4 - 22,9	37 - 65	64 - 74	177 - 520
Rabbit	4,4 - 13,4	4,2 - 8,5	9,8 - 18,0	35 - 50	55 - 75	115 - 941
Cat	5,5 - 19,5	5,0 - 10,0	8,0 - 15,0	24 - 45	39 - 55	300 - 800
Mouse	3,9 - 13,8	6,5 - 10,8	2,1 - 17,0	35 - 47	43 - 56	830 - 2155
Guinea pig	2,2 - 10,8	4,6 - 6,4	12,6 - 16,8	38 - 50	24 - 28	319 - 966
Horse	5,4 - 14,3	6,8 - 12,9	11,0 - 19,0	32 - 53	37 - 59	100 - 350
Rat	4,2 - 17,1	5,1 - 9,1	11,2 - 17,3	32 - 49	48 - 66	335 - 1569
Cow	4,0 - 14,1	6,3 - 10,0	7,6 - 15,5	22 - 43	35 - 59	054 - 640
Sheep	3,2 - 11,9	6,0 - 15,0	8,7 - 15,1	20 - 45	28 - 40	250 - 750
Pig	9,9 - 40,1	4,9 - 8,1	8,3 - 14,5	26 - 45	46 - 64	107 - 605

Calculation Example for Additional Parameters

$$\text{MCH} = \frac{\text{HGB}}{\text{RBC}}$$

$$\text{MCHC} = \frac{\text{HGB}}{\text{HCT}}$$

2 FUNCTIONAL UNITS

2.1 PARTS OF EQUIPMENT

- | | | |
|----------------------|---|--|
| 01. LCD-display | - | display of measuring results, user information |
| 02. Printer | - | for documentation of measurements (without diagram) |
| 04. Number-keys 0-9 | - | keys for entering figures |
| 05. Stop-key | - | to abort activated working cycle |
| 06. Start-key | - | to start all work functions |
| 07. Enter-key | - | to enter, confirm and select |
| 08. Diluter-key | - | for choice of diluter function |
| 09. Mode-key | - | Select menu options |
| 10. Curve-key | - | the distribution curves are displayed on the LCD-Display |
| 11. Cursor-keys | - | to select different points of menu and LCD-setting |
| 12. Print/Enter-key | - | for manual print - confirm and select |
| 13. Dispenser-key | - | to start dispensing isotonic solution |
| 14. Sample Tube | - | to suck in the blood sample |
| 15. Cap. Sample Tube | - | to suck in capillary blood dilution |
| 16. Sample-key | - | to initiate manual working-cycles |
| 17. Green Light | - | signals: ready to suck in |
| 18. Yellow Light | - | signals: system in waiting position |
| 19. Red Light | - | signals: disturbance in the Diluter |
| 20. Cleaning plate | - | for cleaning sample tube |
| 21. Sample Cleaner | - | for cleaning sample tube |

- 22. RBC-Valve - for preparation of RBC-dilution
- 23. WBC-Valve - for preparation of WBC-dilution
- 24. Sample-Valve - for suck in sample-dilution
- 25. WBC-Valve - for transfer WBC-dilution
- 26. Man. Drain-Valve - for manual emptying of measuring chambers (RBC)
- 27. Man. Drain-Valve - for manual emptying of measuring chambers (WBC)
- 28. RBC-Valve - for preparation of RBC-dilution
- 29. Cap. Sample tube - for Cap.-method
- 30. C1-Chamber - WBC-measuring chamber
- 31. C2-Chamber - RBC-measuring chamber
- 32. C2 - RBC-measuring channel C2 consisting of:
 - Aperture-tube 100 um - instrument transformer
 - Reference Electrode - voltage feed
- 33. C1 - WBC-measuring channel C1 consisting of:
 - Aperture-tube 100um - instrument transformer
 - Reference Electrode - voltage feed
 - HGB Suction Probe - probe for the suction of HGB-solution
- 34. C1-Volume unit - for control WBC-measuring-channel
- 35. C2-Volume unit - for control RBC-measuring-channel
- 36. HGB-Unit - for HGB measuring
- 37. Aperture-Tube 100um - instrument transformer (WBC)
- 38. Aperture-Tube 80um - instrument transformer (RBC)
- 39. Electrode - voltage feed
- 40. Power Switch - main switch to switch instrument on and off
- 41. RBC-Valve - for measurement
- 42. Fuse - for mains connection

- 43. Parallel Connector - for printer connection
- 44. Serial Connector - for computer connection
- 46. Waste Bottle - for waste fluids
- 47. Waste Bottle - for waste fluids

2.1.1 Diagram of the Equipment

Dia. 1 The Instrument and its functions (front side)

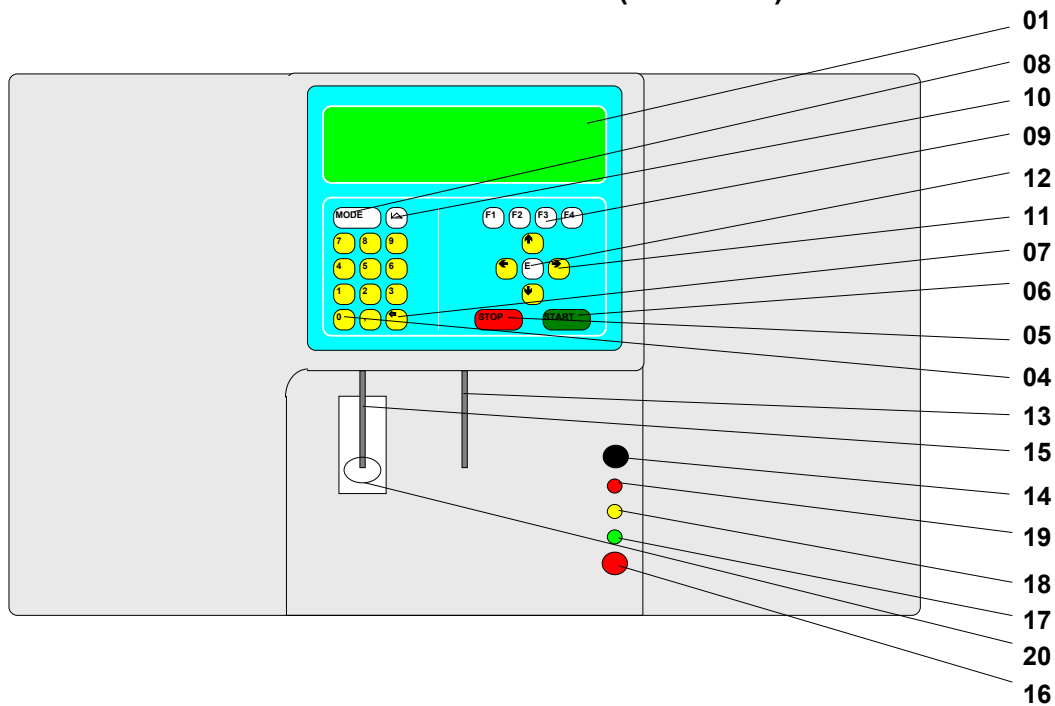

The functional units

01. LC-display	to display measuring results, user information
04. Number keys 0-9	to enter parameters or select options
05. Stop-key	to abort activated working cycle
06. Start-key	to start a working cycle
07. Enter-key	to enter, confirm and select
08. Mode-key	to enter into main menu
09. Diluter-key	to select diluter function
10. Curve-key	to display the distribution histograms
11. Cursor-key	to move the cursor on the display
12. Print/Enter-key	for manual print confirmation
13. Capillary sample tube	to suck in capillary blood dilution
14. Dispenser -key	to start dispensing isotonic solution
15. Sample / Dispense tube	to suck in the blood sample 7 to dispense
16. Man. Sample-key	to initiate working cycles manually
17. Green light	signals: ready to suck in
18. Yellow light	signals: system in waiting position
18. Red light	signals: disturbance in the diluter
20. Sample / Cleaning plate	for cleaning and for sample

2.1.2 Diagram of the Equipment

Dia. 2 The Instrument and its functions (units)

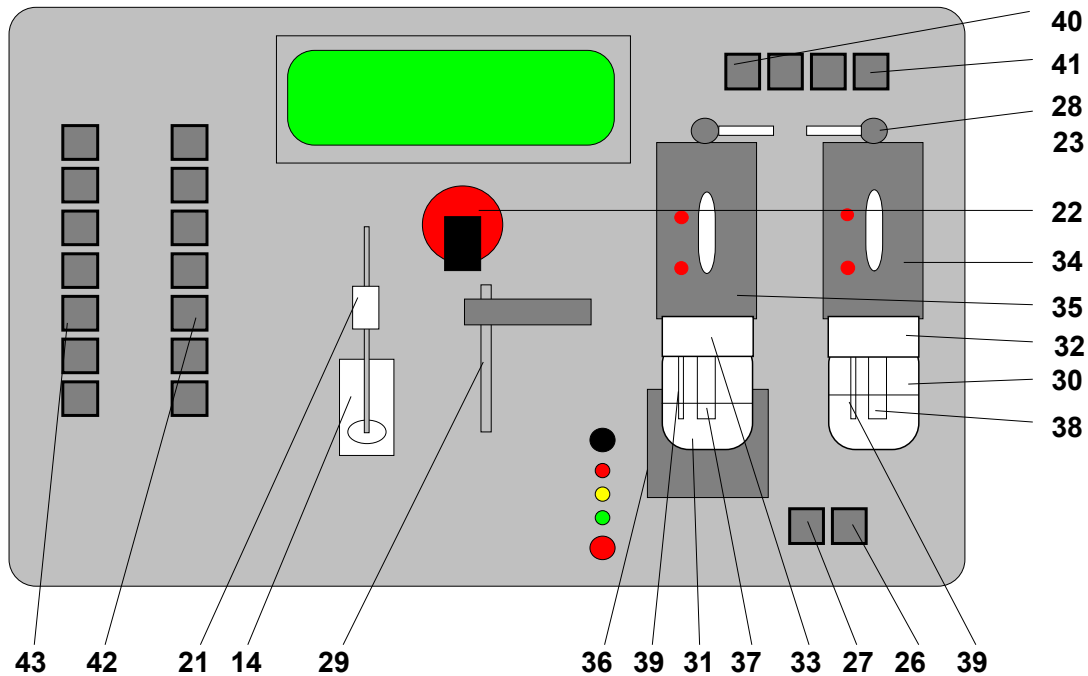

The functional units

- | | |
|---------------------------|--------------------------|
| 21. Sample cleaner | 22. RBC-valve |
| 23. WBC-valve | 26. C2-valve |
| 27. C1-valve | 28. Tube-cap |
| 29. Cap.-sample taker | 30. C2-chamber |
| 31. C1-chamber | 32. C2-channel |
| 33. C1-channel | 34. C2-volume unit |
| 35. C1-volume unit | 36. HGB-unit |
| 37. Capillary 100 μ l | 38. Capillary 80 μ l |
| 39. Electrode | 40. WBC-valve |
| 41. RBC-valve | 42. Diluter-valve (R1) |
| 43. Diluter-valve (R2) | |

2.1.3 Diagram of the Equipment

Dia. 3 The Instrument and its functions (backside)

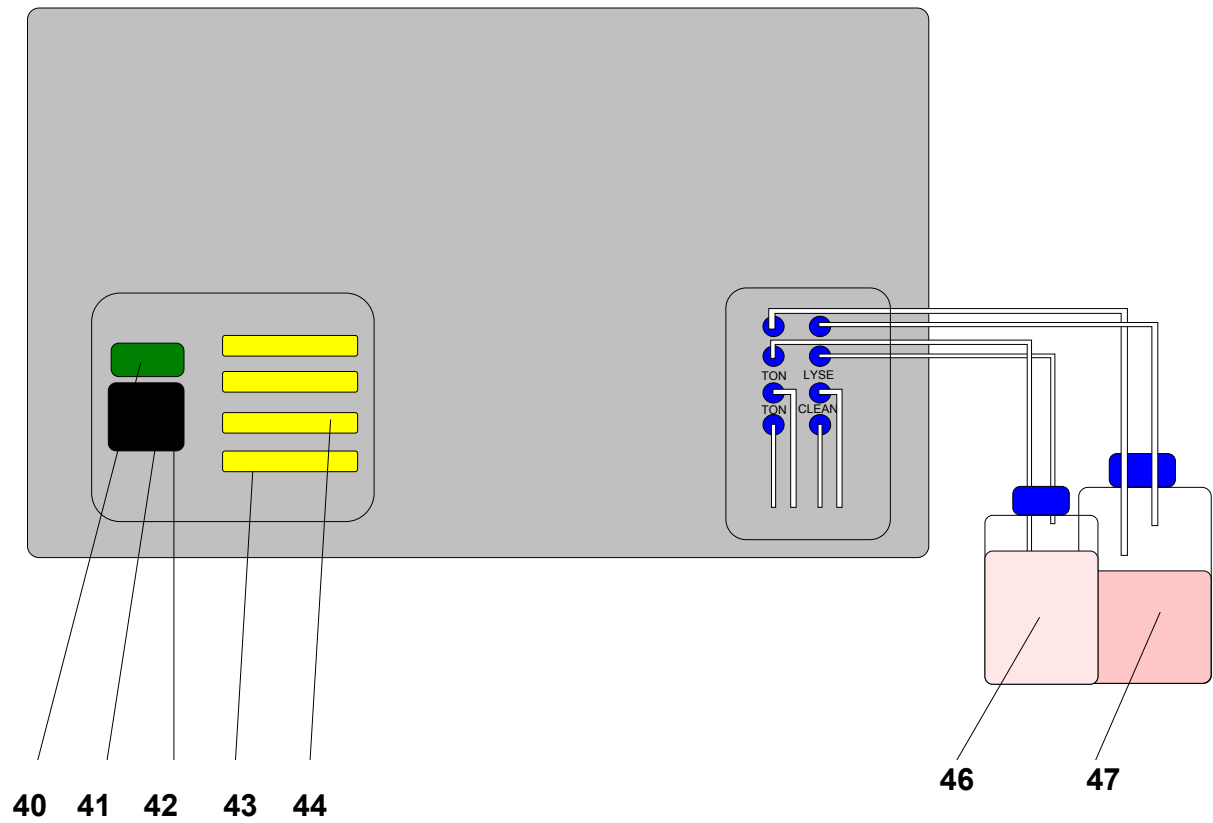

The functional units

- 40. Power switch
- 42. Fuse
- 44. Serial port
- 47. Waste bottle

- 41. Plug
- 43. Parallel port
- 46. Waste bottle

2.1.4 Diagram of the Equipment

Dia. 4 The Keyboard

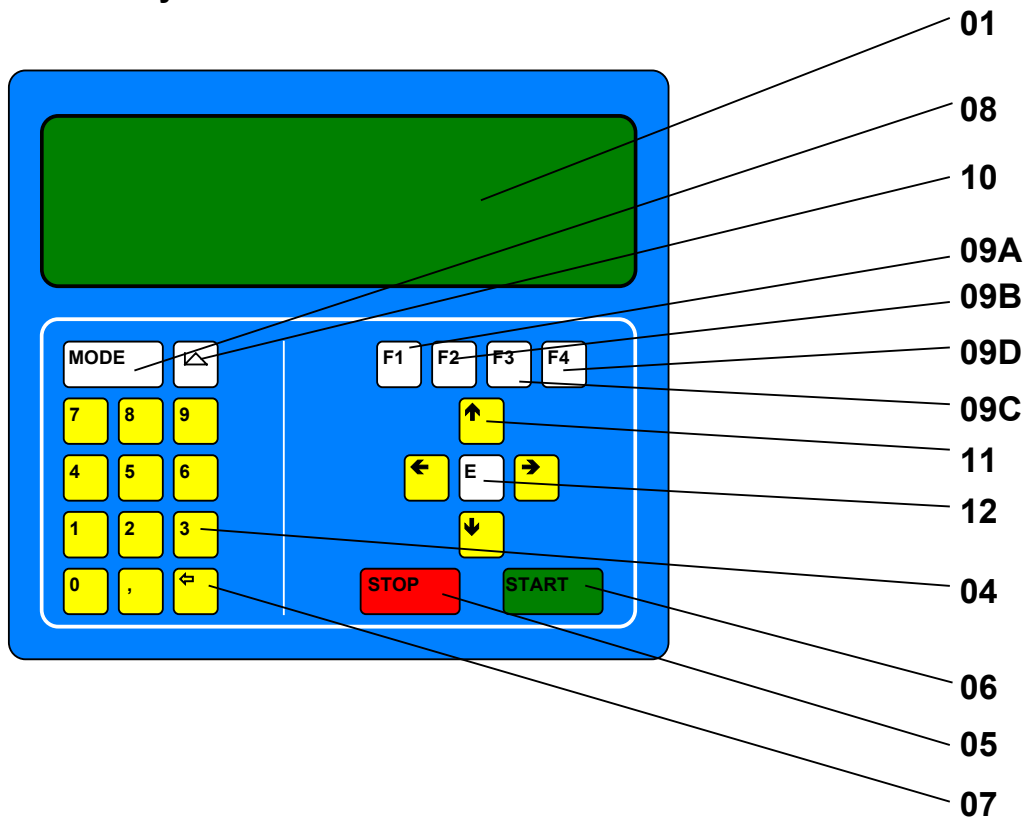

The functional units

- | | |
|------------------------|--------------------------|
| 01. LCD-display | 04. Number keys 0-9 |
| 05. Stop-key | 06. Start-key |
| 07. Enter-key | 08. Mode-key |
| 09. Cello-ton-key (A) | 09. Lyser-key (B) |
| 09. Into operation (C) | 09. Out of operation (D) |
| 10. Curve-key | 11. Cursor-keys |
| 12. Print/Enter-key | |

2.1.5 Diagram of the Equipment

Dia. 5 The Instrument and its functions (tubes and valves)

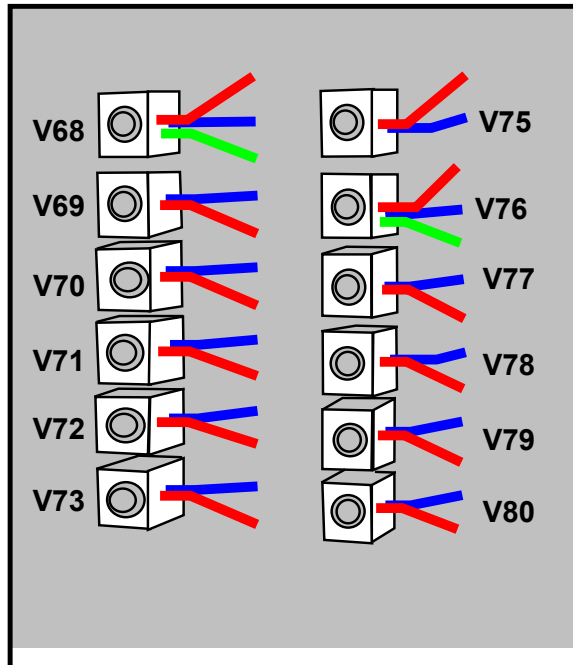

The functional units

- 68. Valve Dispense
- 69. Valve Vacuum (WBC-Inside-Chamber)
- 70. Valve Pressure (WBC-Inside-Chamber)
- 71. Valve Cleaning (Sample-Tip)
- 72. Valve Mixing (WBC-Measuring-Chamber)
- 73. Valve Mixing (RBC-Measuring-Chamber)
- 74. Free
- 75. Valve RBC-Sample
- 76. Valve Capillary Blood/Air
- 77. Valve Empty (WBC- Mixing chamber)
- 78. Valve WBC-Sample
- 79. Valve Out WBC-Solution (WBC-Measuring chamber)
- 80. Valve Waste/Sample
- 81. Free

2.2 UNPACKING THE INSTRUMENT

Please, note, that the automatic **VETanalyzer** has to be installed by a qualified and trained technician.

The following points have to be considered before the instrument will be installed:

1. Check if there are damages on the packing, instrument and accessories.
2. Remove the front-cover (only stuck - not fixed with screws)
Check if all components are fixed correctly.
Remove the cover – and check tubes, plugs, PC-Boards etc. inside the Instrument.
Check the vacuum-pump (fixed with rubber) if it is fixed correctly and remove transport screw.
3. Check the WBC/HGB - chamber if it is fixed correctly.
4. Remove the safety screw from the vacuum pump.
5. Check RBC/WBC-measuring chambers of correct setting.
6. Connect the waste-bottles and supply-canisters and the printer.
The tubes at the back of the instrument are marked accordingly.
7. Connect the instrument and printer with mains and switch on the instrument (backside).
8. Read the manual carefully before you start working.
9. Switch on the instrument and check if all functions are correct.
10. If all functions are correct, close main cover.
11. Fill the counter with **CELLOTON** by pushing **F1-button** for at least 2-3 times.
12. Select in the menu **SYSTEM SETTINGS**, fill the count system by pushing **NUMBER-key "2"** for at least 3 times to carry out a filling cycle.
Push **MODE-key** to go back to the measuring menu.
13. Fill the counter with **CELLOLYSE** by pushing **F2-button** for at least 2 times. After pushing the **F2-button** the **red LED** must be off and the **green LED** must light up.
14. Push **F4-button** to take the instrument **out of operation**.
Switch off the instrument.

15. Switch on the instrument again.
After switching on the instrument automatically will be **taken into operation**.
(If the system does not carry out this cycle, please, push **F3-button**).
16. Close the front-cover (only stuck - not fixed with screws)
17. Carry out some blank measurements.
18. Check correct setting of the **C2-channel** with a zero **HGB-measurement**.
19. Check all menu options and settings. **Autoclean** and **Autostandby** should be chosen.
20. If the function of the instrument is correct, you can start measuring and calibration.

Important Notice:

**When removed the front cover you cannot measure HGB solution.
The WBC-measuring chamber must be dark for an exact result.**

2.2.1 Further Information

For system cleaning use only **CELLOCLEAN^E**. The cleaning solution will be sucked in by a special tube (see marks at the backside of the instrument).

CELLOCLEAN^E only is suitable for 4 weeks at a maximum. We would ask you to check the cleaning solution regularly.
(a fluffy cleaning solution might block the tubes or valves).

Please, activate the dispenser for capillary blood at least once a day as otherwise you might face problems with salt-crystals if it is not used for a longer period of time. The salt crystals might block the metal-tube.

Please, clean the O-ring at the waste-bottle regularly with acid-free grease or silicon-paste.

The valves and tubes have to be checked regularly - if necessary the tubes have to be exchanged.

The **CELLCUPS** are only for capillary method.

Not all controls are suitable as some are extremely viscous.

We recommend controls which are tested by us.

If you use other controls, we recommend to clean the blood needle after using, with **CELLOTON** (carry out a blank-measurement) after you have measured the sample so that you avoid a carry-over.

**Adjust blood- , capillary- and dispenser needle if is necessary.
For special blood needle ask your distributor.**

2.2.2 Fitting of the Capillary

As seen in Dia. 2, the aperture-tube is mounted into the measuring chamber as follows:

The aperture-tube is inserted into screw-lid. Then the aperture-tube is mounted into the socket with moderate strength.

Aperture diameter for channel (left) C1 = 100 μ m
Aperture diameter for channel (right) C2 = 80 μ m

Dia. 8 Fitting of the capillary.

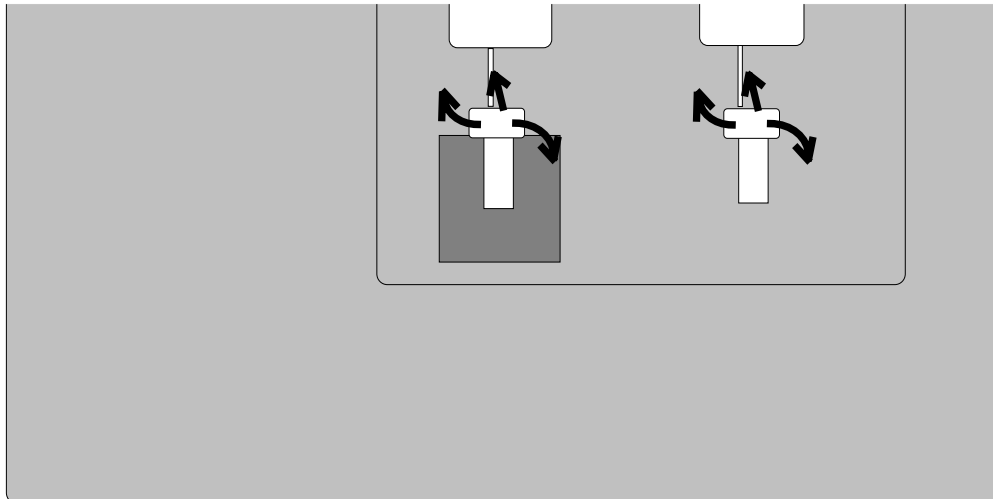

Important Notice:

After change of the capillary the correct fixing of the capillary has to be checked as a wrong fixing will influence the HGB-measurement.

The measuring chamber must fit closely to the reverse-side/right side.

This can be checked after a determination of the blank solution in the menu “HGB-settings” which can be found in the service menu.

The chamber has to be adjusted exactly so that the measured result is between – 1.5 and +1.5.

Please, note that no light source will shine on the measuring chamber directly.

2.3 WHAT YOU MUST KNOW IN ANY CASE

Even if you do not like to read manuals you should at least study the following passage.

The instrument must in all cases be installed by a service technician who will introduce the operators of the instrument to the functions and handling of the system.

After the instrument was switched on it automatically performs a self-test and checks its components on their function.

In case a defect should be diagnosed, the system branches into an error menu and reports the error on the display. In this situation the help-menu can be called up which gives an explanation of the display and possibly offers a problem solution.

Naturally, an automatic system can only offer standardized proposals for problem-solutions that can not in every case be exactly to the point.

However, after some experience with the instrument, you will be able to interpret the error indications correctly.

After the self-test is completed the following display appears on the display:

Display

ALvet300 SELFTEST.	IS FINISHED
RBC ANALYSER 1.0 (e.g.)	
WBC ANALYSER 1.0 (e.g.)	
DILUTER 1.3 (e.g.)	
SPOOLER 1.3 (e.g.)	
MEMORY O.K.	PUSH ANY BUTTON !

2.3.1 Important Advice

The instrument controls all important functions, as well as supply and waste containers. In order to avoid unnecessary disturbances in the working routine the control units are set up to accept a certain range of allowance.

For this reason it is particularly important that the waste containers are closed tightly, as even a small uptightness might cause problems in the measuring routine.

The overflow control of the waste bottles is photo-optically controlled, so that some drops on the control sensors can cause the system to wrongly report an error.

Here are the most important points to remember:

Always close waste containers tightly as the system works with vacuum.

Check safety bottle regularly as an overflow of this bottle will cause the destruction of the vacuum unit.

Check and clean capillaries regularly since cracks or pollution will distort the measuring results.

Check supply containers for contamination and clean or replace them when necessary.

Check and clean mixing and measuring chamber regularly.

Use only original measuring solutions or solution of approved quality.

Use only solutions with an acceptable blank value. After replacing the supply container always check with a blank value determination.

Have the instrument checked regularly by a service technician.

Clean the instrument regularly with proper cleaning solution.

Never let measuring solutions stand inside the system for a longer period or time.

Clean HGB cuvette with special cleaning solution every week.

Do not make any changes in the service menu.

2.4 THE LCD - DISPLAY

The "**status**" inform about the working cycles, the system-status and the possibilities of entering commands or data.

The display further has a menu sector on which the measuring results, the system features and explanations are displayed.

Display

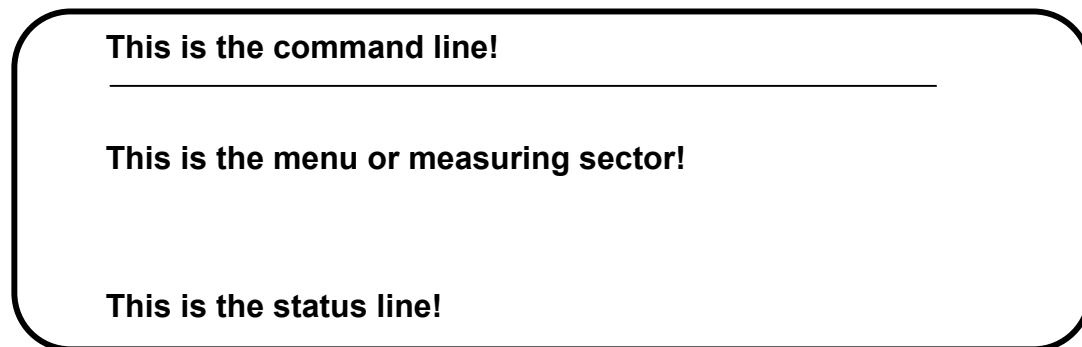

The status line -

informs on possibilities of input or the momentary state of operation.

The menu or measuring sector -

allows to choose the system features and the parameters that are to be measured and displays the measurement results.

The command line -

informs on possibilities of input or the momentary state of operation.

2.4.1 The Standard or Measuring Menu

The following display appears during the normal operating mode. It shows all important system information that are needed for the normal working routine.

- The status line** informs on the present working mode.
- The patient-identification-number** can be entered for each sample separately. If the patient ID is other than zero, the printer will wait for confirmation or change of the ID-number that was entered before it prints out.
- The sample number** will count on in sequence and document the samples. Samples that are not documented by print-out will not affect the sample count. The count starts from the number that was entered.
- The date display** is not controlled by a real-time clock so that the new date has to be entered each day.
- The measuring time** informs about the condition of the capillaries and the vacuum system.
- The measuring menu** displays the measured results of the activated parameters.

Display

CH1:	0.0	No: 000000	[12:31:15]
CH2:	0.0	ID: 000000	[DOG]

RBC:	0.0	HCT: 0.0	MCV: 0.0
WBC:	0.0	LYM: 0.0	MPV: 0.0
THR:	0.0	MID: 0.0	MCHC: 0.0
HGB:	0.0	GRA: 0.0	MCH: 0.0
READY FOR MEASUREMENT			← ANIMAL →

Note:
With the arrow keys the animal can be changed.

2.4.2 The Graphic Menu

The following diagram appears if the curve-key will be pushed.

The diagram shows all necessary information which are important for the control of the measurements.

By using the up and down key a selection of the individual curve is possible.

Display

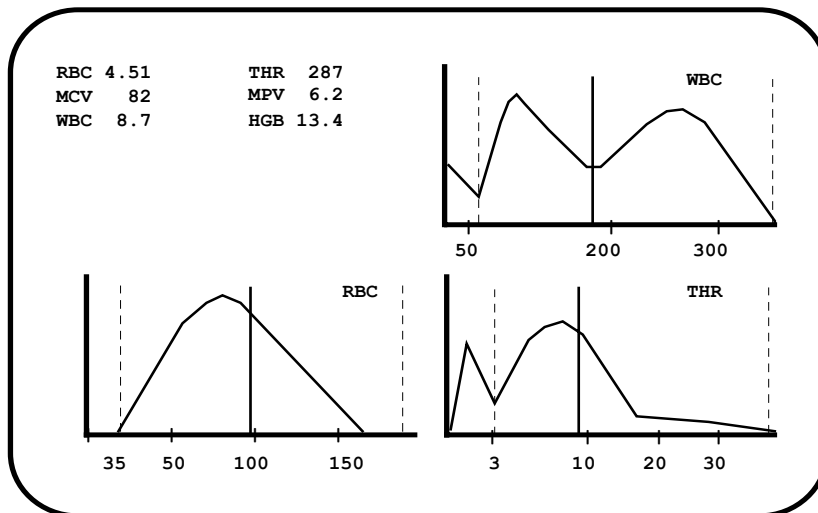

2.5 THE FUNCTIONAL KEYS

The system is equipped with functional keys which execute a command directly. The advantage of this is that no selection has to be carried out through submenus.

2.5.1 The MODE-key

leads through the sub- and selection menus. If special functions are required, it is necessary to use this key.

2.5.2 The CURVE-key

gives access to the distribution curves. By mean of these histograms the different particle populations can be controlled on the display.

In the event of an abnormal distribution the histograms will be automatically displayed on the display so that a judgment on pathological results is possible.

2.5.3 The ENTER-key

is used for input, selection or confirmation. This can be observed either through brighter appearance, underlying, dis- and re-appearance of specific displays.

2.5.4 The CURSOR-Keys

are as a rule used in combination. By moving the cursor a choice is made, by pressing the **ENTER-key** the function or the data on which the cursor stands is confirmed.

The chosen sector will be marked.

The cursor normally moves vertically and automatically jumps from the deepest point back to the start line when moved further in that direction. Only in the line of the patient's identification number, the sample number and the date the cursor moves horizontally.

-To adjust the contrast of the LCD-display use cursor up and down.

-To move WBC-discriminator left or right use cursor up and down.

2.5.5 The E-PRINT-key

is a special function key for the print-out. It serves to receive print-outs of results with error marks or of results that were already printed out.

2.5.6 The START-key

serves to start a measurement. It can be used for a multiple determination of a sample. However, it has to be taken into consideration that the system can only measure once without danger of drawing air bubbles on channel 2 unless the HGB-channel was switched off.

2.5.7 The STOP-key

abort the measuring cycle of the measuring system, while the cycles of the Diluter will not be interrupted.

The Diluter functions can only be aborted in the service menu by Diluter-reset. This serves to prevent that a sample that has already been sucked in is lost.

2.5.8 The NUMBER-keys

are needed to execute numerical inputs and modifications. It has to be noticed that the system can only accept inputs that are within the range that appears in the status line.

2.5.9 F1-Taste

is filling the Diluter system with **CELLOTON** from the supply canister.

2.5.10 F2-Taste

is filling the Diluter system with **CELLOLYSE** from the supply canister.

2.5.11 F3-Taste

take the system after **OUT OF OPERATION** in **INTO OPERATION**.

2.5.12 F4-Taste

take the system **INTO OPERATION**.

3 WORKING WITH THE INSTRUMENT

3.1 ENTERING DATE, SAMPLE AND ID-NUMBER

Choose the desired input sector (figure shines brighter) by using the cursor and confirm this by pushing the **ENTER-key**.

The chosen sector will now be marked and the desired data can be typed in by the keyboard. By pushing the **ENTER-key**, you confirm the entered data and the marked field disappears.

3.2 SYSTEM HANDLING

Check if there is solution in the measuring chambers. Normally, this is the case if the instrument has gone through

"TAKING OUT OF OPERATION or TAKING INTO OPERATION"
to switch it on or off.

Start the measurement of a blank solution by pressing the **START-key**. This way it is checked if the aperture-tubes and the measuring solution are in working condition.

In the status line, the following appears:

MEASURING

This way the service line informs that the measuring can be interrupted by pressing the **STOP-key**.

After measuring, the measuring time and the determined background of channel **C1** and **C2** are displayed.

The system will check the results and reject them with an error-report or will accept them by the following display :

READY FOR MEASUREMENT

3.2.1 The Blank Values

The blank values are o.k. for:

RBC up to 0,07

WBC up to 00,7

HGB up to 00,5

THR up to 050

PRP up to 045

Is the value to height then repeat an zero measurement.

After these values were reached the measuring of samples can be started.
(compare section sample preparation)

3.2.2 The Dilution Station

The dilution station serves to process the blood samples to the proper dilution ratio and consists of:

A burning green light signals that the diluting station is ready.

In the status line, the following appears:

READY FOR MEASUREMENT

Take a blood sample under the sample tube. The sample will be sucked in as soon as the light barrier will be activated.

The sample tube will be automatically cleaned!

After the sample tube was cleaned, the next working step can be started by placing the next blood sample under the sample tube.

Now, the sample that was sucked in, is automatically processed and the results are displayed on the display when the measurement is finished.

The individual steps of the sample processing are shown in the status line.

3.2.3 The Sample Sequence

Usually the lysing reagent requires a waiting period of about 5 to 20 seconds for processing the leukocyte/hemoglobin measuring solution (check manufacturer notice "lysing reagent").

It is possible and recommended to use this time for sucking in the next sample.

This way the sample sequence can be increased considerably.

3.3 DOCUMENTATION OF MEASUREMENT RESULTS

All measured values can be documented through a print-out.

3.3.1 The Graphic Print-out

The use of a computer printer offers the possibility to also have the distribution curves documented.

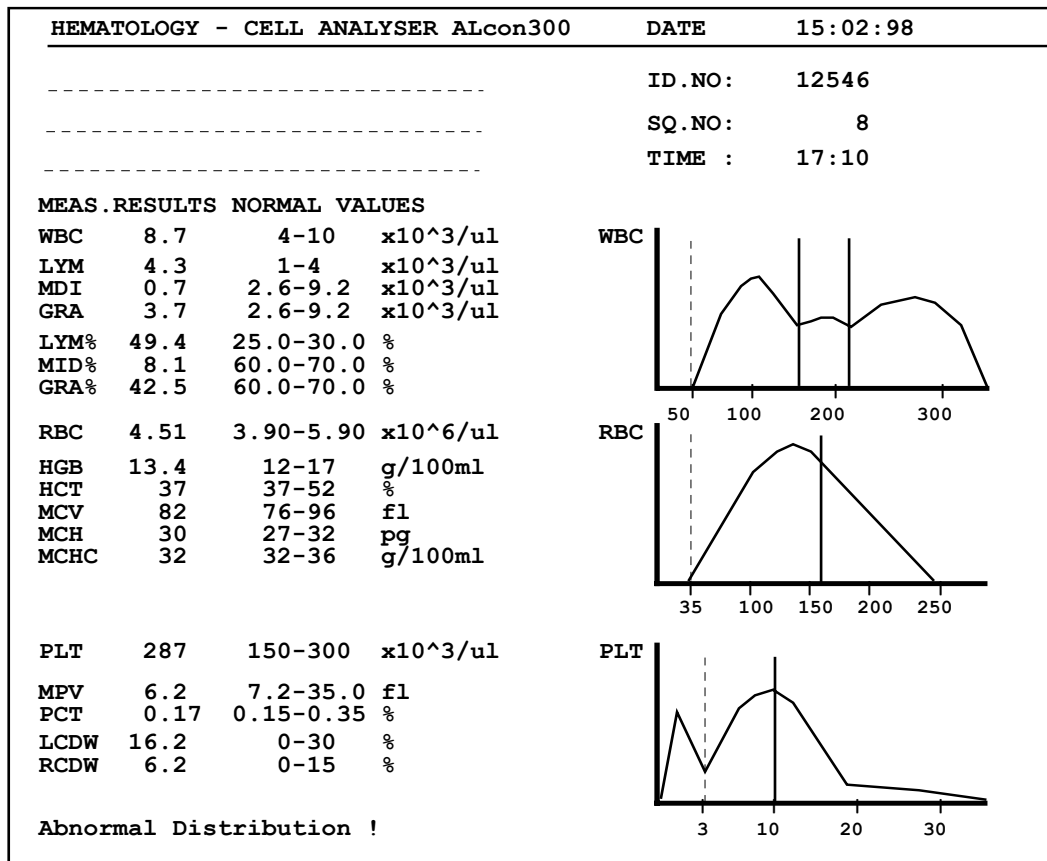

3.3.2 The Ticket Print-out

The use of a computer printer offers the possibility to have a ticket printing documentation.

AL300 CELLCOUNTER			
DATE :	12.02.98		
ID.NO:	12546		
SQ.NO:	16		

MEAS. RESULTS NORMAL VALUES			

WBC	8.7	4-10	x10 ³ /ul
LYM	4.3	1-4	x10 ³ /ul
MID	0.7	2.6-9.2	x10 ³ /ul
GRA	3.7	2.6-9.2	x10 ³ /ul
LYM%	49.4	25.0-30.0	%
MID%	8.1	60.0-70.0	%
GRA%	42.5	60.0-70.0	%
RBC	4.51	3.90-5.90	x10 ⁶ /ul
HGB	13.4	12-17	g/100ml
HCT	37	37-52	%
MCV	82	76-96	fl
MCH	30	27-32	pg
MCHC	32	32-36	g/100ml
PLT	287	150-300	x10 ³ /ul
MPV	6.2	7.2-35.0	fl
PCT	0.17	0.15-0.35	%
LCDW	16.2	0-30	%
RCDW	6.2	0-15	%

4 ROOTMENU

4.1 SELECTION OF SYSTEM FEATURES

The **selection of system features** is called up through the **MODE-key**. As not all functions and parameters are always needed, it is possible to change them or switch them off or to use them through a certain menu.

When pressing the **MODE-key**, the menu **SYSTEM FEATURES** will appear on the display.

Display

SYSTEM SETTINGS:

1 PARAMETERS	7 CAPILLARY REPLACE
2 FILL	8 DATABASE
3 CLEAN	9 SET ANIMAL
4 CALIBRATION	→SET NORMAL VALUES
5 SERVICE	←SET PARAMETER
6 OPTIONS	E PRINTOUT

The desired menu point can be reached by using the corresponding **Number-keys**.

4.1.1 Select Parameters

In this menu, a desired function that was selected through the cursor can be turned on or off.

Display

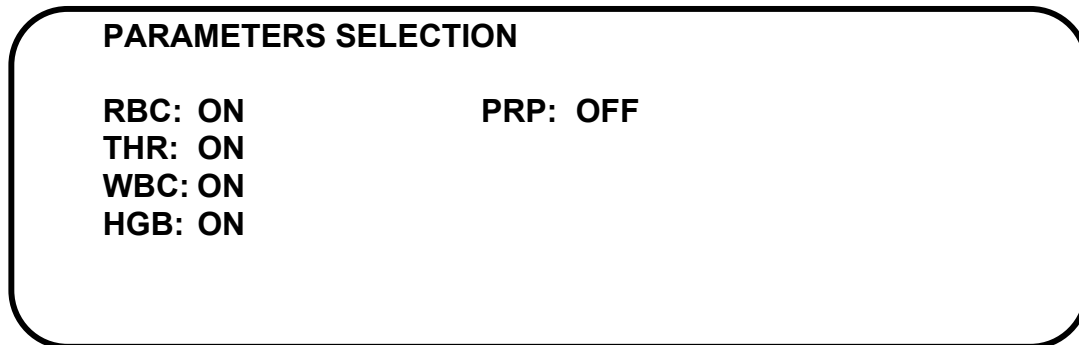

By pressing the **ENTER-key** the parameter can be selected.

When the entering is completed you can return to the main menu by pressing the **MODE-key**.

Alternatively, this is also possible by pressing the **START-key**.

4.1.2 PRP Blood

If this mode is switched on, all other measuring parameters are automatically switched off.

The PRP-mode is used to determine Platelets (Thrombozytes) from Platelet Rich Plasma (PRP) according to the Dextran T 500 method.
(check section "preparing samples")

4.1.3 RBC, THR/PLT, WBC, HGB

Any other parameters (measuring sectors) can be combined in open choice.

The calculated parameters that are correlated with the measured parameters are automatically switched on and off with the parameters that they depend on.

4.1.4 Cap Pressure

In this menu point, the program does not branch to a submenu. When the **ENTER-key** is pressed, the aperture-tubes will be cleaned by counter-pressure. However, please note that the solution standing under the capillaries is soiled.

Display

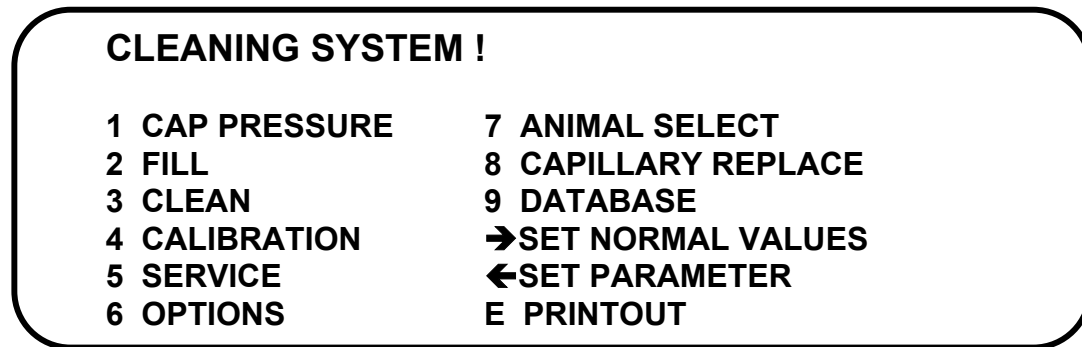

After selecting **NUMBER-key "1"** the system now goes proceeds a cleaning cycle.

4.1.5 Fill

In this menu point, the program does not branch to a submenu. When the **ENTER-key** is pressed, the measuring channels are filled. Make sure that there is enough liquid in the measuring cups to cover capillary apertures when activating this point.

Display

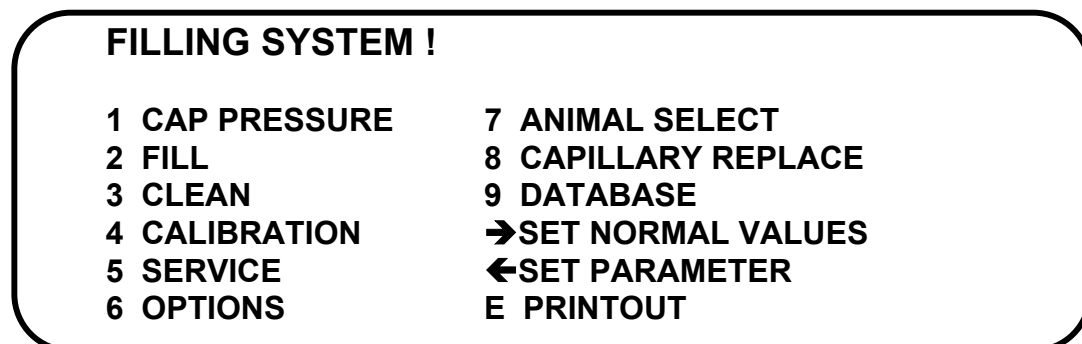

After selecting **NUMBER-key "2"** the system now proceeds a filling cycle.

4.1.6 Clean

In this menu point, the program does not branch to a submenu. When the **ENTER-key** is pressed, the system will be completely cleaned by cleaning solution.

Display

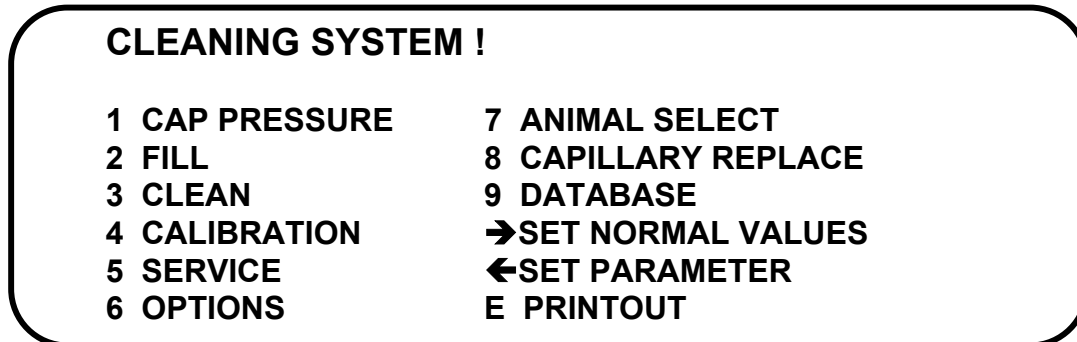

After selecting **NUMBER-key "3"** the system now goes proceeds a cleaning cycle.

4.1.7 Calibration of Standard Values (whole-blood-mode)

In this menu point, the program branches to the calibration menu when the **NUMBER-key "4"** in the **SYSTEM SETTINGS** menu is pushed.

Display

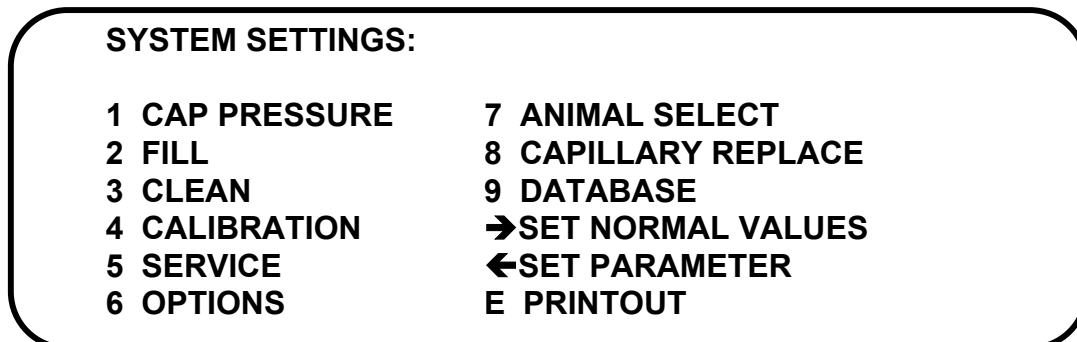

In this menu point, the program branches to the calibration menu, according to the selected mode.

4.1.8 Calibration of Standard Values

In this menu point the calibration mode can be switched on or off.

Display

CALIBRATE	(N)

ENABLE CALIBRATION:	
	CALIBRATION: OFF
	ERASE

Start a measuring with **control blood** in the **normal-blood mode** .
After the measurement the program will branch into either
of the following menus.

Display

CALIBRATE	(N)

N RBC: 4.56	LYM : 5.50
N THR: 225	MID: 2.6
N WBC: 8.0	MCV: 90.0
N HGB : 14.5	MPV: 8.2
N HCT: 42.0	CALIBRATION: ON
	ERASE

In this menu, the measured values can be calibrated or adjusted.

Place cursor on the required value and push **ENTER-key**.

The value can be adjusted now.

Return to the measuring menu by pushing the **MODE-key**.

Notice:

The calibration can be carried out only in the normal range!

4.1.9 Calibration of Standard Values (capillary-blood-mode)

Start a measuring with **control blood** in the **capillary-blood mode** .
After the measurement the program will branch into either
of the following menus.

Display

CALIBRATE		(N)
C	RBC: 4.56	LYM : 5.50
C	THR: 225	MID: 2.6
C	WBC: 8.0	MCV: 90.0
C	HGB : 14.5	MPV: 8.2
C	HCT: 42.0	CALIBRATION: ON
		ERASE

In this menu, the measured values can be calibrated or adjusted.

Place cursor on the required value and push **ENTER-key**.

The value can be adjusted now.

Return to the measuring menu by pushing the **MODE-key**.

Notice:

The calibration can be carried out in the normal range only!

4.1.10 Erase mode

When the calibration was wrong the factory value can be set.

Display

SWITCH INSTRUMENT OFF AND ON !!!		
C	RBC: 4.56	LYM : 5.50
C	THR: 225	MID: 2.6
C	WBC: 8.0	MCV: 90.0
C	HGB : 14.5	MPV: 8.2
C	HCT: 42.0	CALIBRATION: ON
		ERASE

Place cursor on the menu point **ERASE** and press **ENTER-key**.

Now the factory setting for all parameters and levels will be used.

For **ERASE** use only arrow key.

4.1.11 Service

In this menu point, a technician can make system-checks and adjustments.

Display

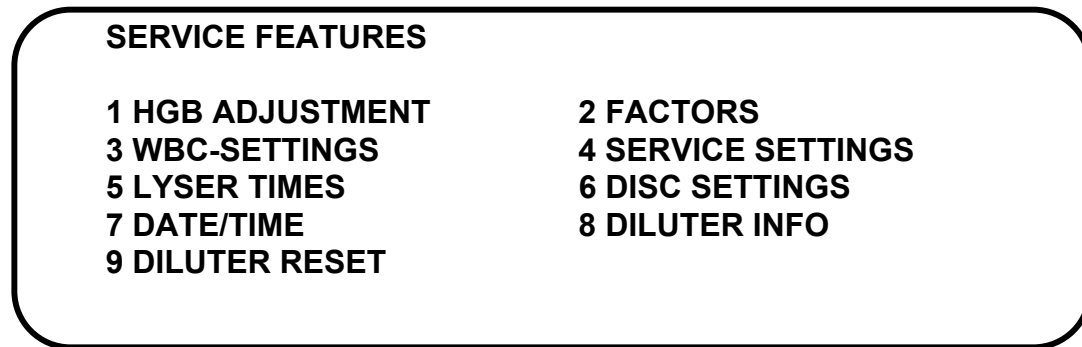

In this menu point, the program branches to the service menu when the Corresponding number-key is pressed.

Attention !

This sector is only needed for the service, however, some functions can be used or looked at to get information on system errors.

DO NOT MAKE ANY CHANGES ! EVEN A SMALL CHANGE CAN SERIOUSLY AFFECT THE FUNCTIONING OF THE SYSTEM !!

For adjustment the WBC-differentiation use only point 5 and 6.

4.1.12 Options

In this menu point the printing setting criteria can be entered.

In this menu point, the program branches to the **system options menu** if the **ENTER-key** is pressed.

Display

SYSTEM SETTINGS		→,←	
AUTO	: ON	PAPER	: 12 INCH
PARALLEL	: ON	PRINTER EMUL	: IBM
RS232	: OFF	AUTO STANDBY	: OFF
BAUD	: 9600	AUTOCLEAN	: ON (50)
S.I.	: OFF	BLOOD SAVING	: OFF
HGB	: GRAM	AUTO DIFF	: ON

By pressing **ENTER-key** the system options can be switched **on** and **off** or selected line options.

4.1.13 Standby-Mode

The system is always in a standby position when no samples are measured.

However, as blood samples always cause pollution it should be avoided to let blood samples in the instrument for a longer period of time.

In normal laboratory routine interruptions can occur, so that the instrument is not used for a while.

When the System is not used for some time and the automatic standby-mode is switched on, the system carries out this procedure after 20 minutes automatically.

By activating the standby mode the solution in the measuring chambers, the capillaries will be replaced, so that possible pollution is avoided.

The STANDBY-mode does not bring the system into a different working condition but is meant to allow a continuation of sample processing after an interruption.

Thus, it is not necessary to take it out of operation.

When the system is in the standby-mode no extra steps have to be taken when you want to continue measuring. Just start a normal measurement.

Display

SYSTEM SETTINGS		→,←	
AUTO	: ON	PAPER	: 12 INCH
PARALLEL	: ON	PRINTER EMUL	: IBM
RS232	: OFF	AUTO STANDBY	: OFF
BAUD	: 9600	AUTOCLEAN	: ON (30)
S.I.	: OFF	BLOOD SAVING	: OFF
HGB	: GRAM	AUTO DIFF	: ON

By pressing **ENTER-key** the system options can be switched **on** and **off** or selected line options.

Notice:

The STANDBY-mode should always be chosen when there is an interruption in the measuring routine or when you do not know when the next sample will be processed.

These way problems of pollution that might influence the next measurement can be avoided.

You can start the next measurement without any further procedures.

4.1.14 Auto-Clean-Mode

The problem of the human blood will by proteins, grease and micro clods. This can block the capillary. For a good running of the instrument the system must be cleaned during the routine work.

Is the **AUTOCLEAN MODE ON**, the system will be cleaned after the registered sample sequence.

In this case the display will answer you for **YES** or **NO**.

By activating the AUTOCLEAN MODE the solution in the measuring chambers and the capillaries will be replaced, so that possible pollution is avoided.

If auto clean mode is activated the sample tube should be also cleaned with Celloclean^E. The display ask for this function.

The AUTOCLEAN MODE does not bring the system into a different working condition but is meant to allow a continuation of sample processing after an interruption.

When the system is in the **AUTOCLEAN MODE** no extra steps have to be taken when you want to continue measuring. Just start a normal measurement.

Display

SYSTEM SETTINGS		→,←	
AUTO	: ON	PAPER	: 12 INCH
PARALLEL	: ON	PRINTER EMUL	: IBM
RS232	: OFF	AUTO STANDBY	: ON
BAUD	: 9600	AUTOCLEAN	: ON (50)
S.I.	: OFF	BLOOD SAVING	: OFF
HGB	: GRAM	AUTO DIFF	: ON

By pressing **ENTER-key** the system options can be switched **on** and **off** or selected line options.

Notice:

The AUTOCLEAN MODE should always be chosen when the display offers this menu point.

This way problems of pollution that might influence the next measurement can be avoided.

You can start the next measurement without any further procedures.

4.1.15 The Blood-Saving-Mode

Is the **BLOOD-SAVINGS MODE** switches on, blood will be only sucked to the first sample detector.

After removing the sample the system sucks the blood up to the second sample detector. Thereby the blood consumption will be reduced.

Therefore this option is suitable specially for the working with control-blood.

But some controls on the market has a different viscosity, in this case it is possible the transfer time in the option "**TRANSFER.**" In the set-menu must be changed.

An adjustment could be executed only experimental.

Display

SYSTEM SETTINGS		→,←	
AUTO	: ON	PAPER	: 12 INCH
PARALLEL	: ON	PRINTER EMUL	: IBM
RS232	: OFF	AUTO STANDBY	: ON
BAUD	: 9600	AUTOCLEAN	: ON (50)
S.I.	: OFF	BLOOD SAVING	: OFF
HGB	: GRAM	AUTO DIFF	: ON

Notice:

A changes from control- to human blood could make it necessarily to change the adjustment of the transfer time.

If blood sucked in with the Man.-button, a confirmation with this button its led.

4.1.16 The Auto-Diff-Mode

Is the **Auto-Diff-Mode** switched on, the three-part-diff setting will be activated.

Display

SYSTEM SETTINGS		→,←	
AUTO	: ON	PAPER	: 12 INCH
PARALLEL	: ON	PRINTER EMUL	: IBM
RS232	: OFF	AUTO STANDBY	: ON
BAUD	: 9600	AUTOCLEAN	: ON (50)
S.I.	: OFF	BLOOD SAVING	: OFF
HGB	: GRAM	AUTO DIFF	: ON

Important Notice:

Is the application of the **Auto-Diff-Mode** is chosen, the three-part-diff will be used. The system use the discriminator and thresholds from service settings for the calculation.

If the discriminator setting is zero, the three-part-diff will be not used for this animal.

For using an changing compare Service-Settings (Diff-Parameter).

4.1.17 Animal Select

In this menu point, the program branches to the animal menu when the **NUMBER-key "7"** in the **SYSTEM SETTINGS** menu is pushed.

Display

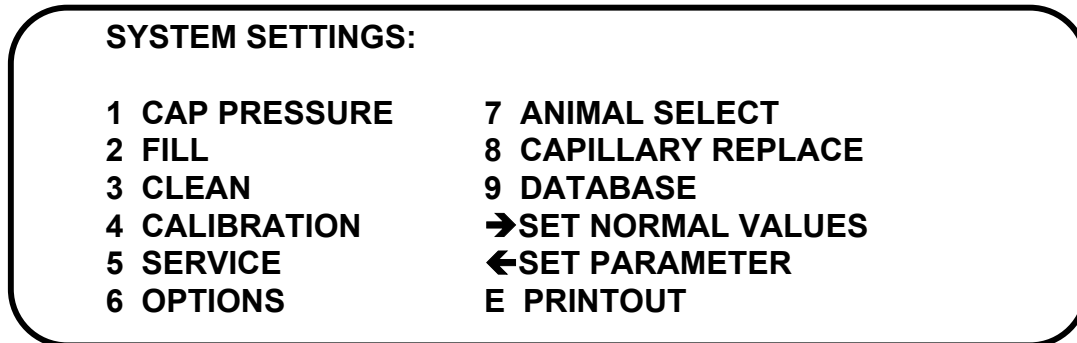

In this menu point, the program branches to the animal menu, the animal can be changed in the selected mode.

4.1.18 Capillary replacement

Only will be used if it is necessary to change the capillary. If activated, the measuring chambers will be emptied so that the capillaries can be removed.

Display

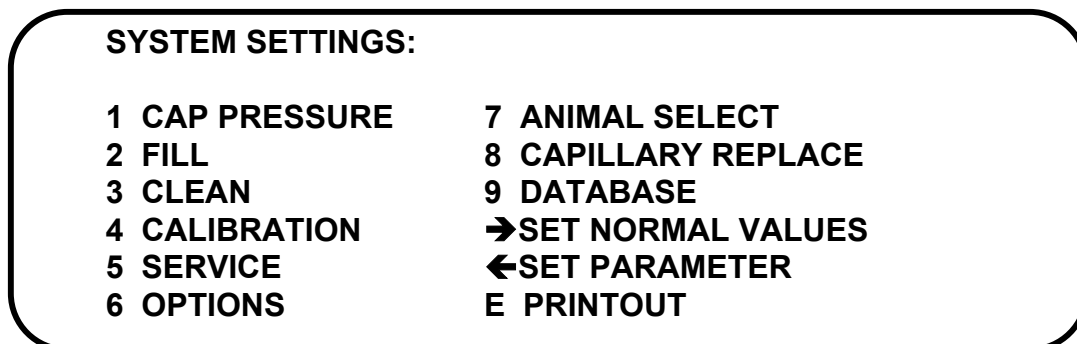

FOR CAPILLARY REPLACE FOLLOW SERVICE LINE IN THE DISPLAY

Please, select with **NUMBER-key "8"** in the main menu.

4.1.19 DATABASE FEATURES

The **selection of database features** is called up through the **NUMBER-key “9”**.
The **database** offers a capacity of up to **250 samples**.

The following menu points can be activated by selecting with the corresponding number-key:

Display

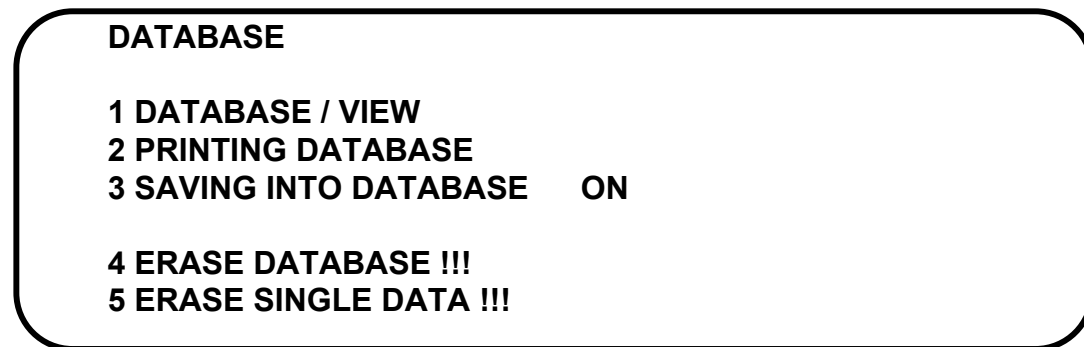

With the up and down key samples can be selected in the sub-menu.
With left and right key the parameters can be selected.

4.1.20 Display Database

In this menu point, the program branches to the **DATABASE MENU** when the **NUMBER-key "1"** in the **DATABASE MENU** is pressed.

Display

BLOCK: 1/1		SAMPLE: 5				PAGE: 1	
NO.	RBC	WBC	HGB	HCT	MCV	THR	DAT/ID
01	4.52	9.5	13.2	38	87	221	123456
02	4.42	7.5	13.5	37	85	272	345678
03	5.58	9.6	16.4	49	89	424	123561
04	4.22	5.5	12.6	36	87	121	345622
05	3.52	4.5	11.2	30	82	325	123457

Which the **CURSOR-key** you can select between the different parameters.
(three pages on the display)

Display

BLOCK: 1/1		SAMPLE: 5				PAGE: 1	
NO.	RBC	WBC	HGB	HCT	MCV	THR	DAT/ID
01	4.52	9.5	13.2	38	87	221	123456
02*	4.42	7.5	13.5	37	85	272	345678
03L	5.58	9.6	16.4	49	89	424	123561
04M	4.22	5.5	12.6	36	87	121	345622
05R	3.52	4.5	11.2	30	82	325	123457

4.1.21 Unselect a Sample

If the users want to unselected a sample that is not suitable for statistic, the following steps are necessary.

Display

BLOCK: 1/1		SAMPLE: 5				PAGE: 1	
NO.	RBC	WBC	HGB	HCT	MCV	THR	DAT/ID
01	4.52	9.5	13.2	38	87	221	123456
02	4.42	7.5	13.5	37	85	272	345678
03	5.58	9.6	16.4	49	89	424	123561
04	4.22	5.5	12.6	36	87	121	345622
05	3.52	4.5	11.2	30	82	325	123457

Select the corresponding page with the sample number that has to be unselected.

Display

BLOCK: 1/1		SAMPLE: 5				PAGE: 1	
NO.	RBC	WBC	HGB	HCT	MCV	THR	DAT/ID
01	4.52	9.5	13.2	38	87	221	123456
02	4.42	7.5	13.5	37	85	272	345678
03	5.58	9.6	16.4	49	89	424	123561
04	4.22	5.5	12.6	36	87	121	345622
05*	3.52	4.5	11.2	30	82	325	123457

Press the last number of the sample on the keyboard.

(for example "5" for sample No. "05").

The sample that should not be considered is now marked with "*".

4.1.22 Result is marked with "L", "M", "R" or "?"

If a result is marked with "I", "L", "M", or "R" the **THR-distribution-curve** is not correct.

If a result is marked with "?" the corresponding parameter (WBC, RBC, THR, MPV) is out of range of the linearity (same as in the main menu).

Display

BLOCK: 1/1		SAMPLE: 5				PAGE: 1	
NO.	RBC	WBC	HGB	HCT	MCV	THR	DAT/ID
01	4.52	9.5	13.2	38	87	221	123456
02*	4.42	7.5	13.5	37	85	272	345678
03L	5.58	9.6	16.4	49	89	424	123561
04M	4.22	5.5	12.6	36	87	121	345622
05R	3.52	4.5	11.2	30	82	325	123457

4.1.23 SAVING INTO DATABASE

In this menu point the **option to save data** can be switched **on** or **off**.

Display

DATABASE / STATISTICS	
1 DATABASE / VIEW	
2 PRINTING DATABASE	
3 SAVING INTO DATABASE	ON
4 ERASE DATABASE !!!	
5 ERASE SINGLE DATA !!!	

4.1.24 Erase Database

In the **MENU POINT 4 or 5** all or single data can be deleted.

Display

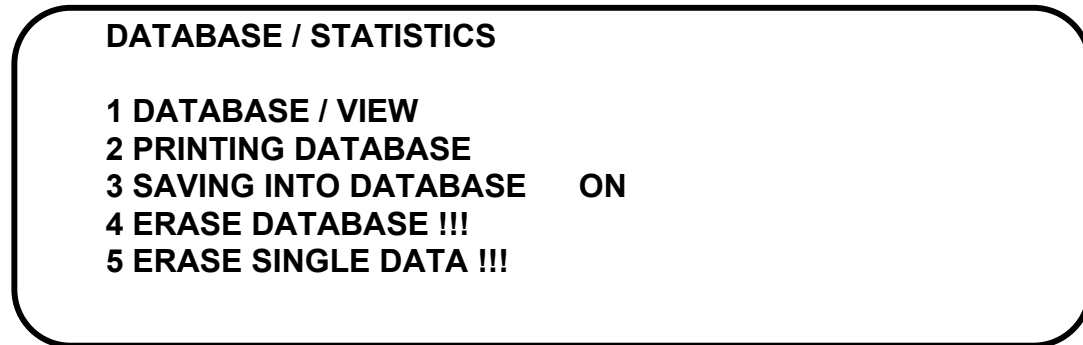

When **NUMBER-key "4 or 5"** is pressed the computer asks the user to confirm.

Display

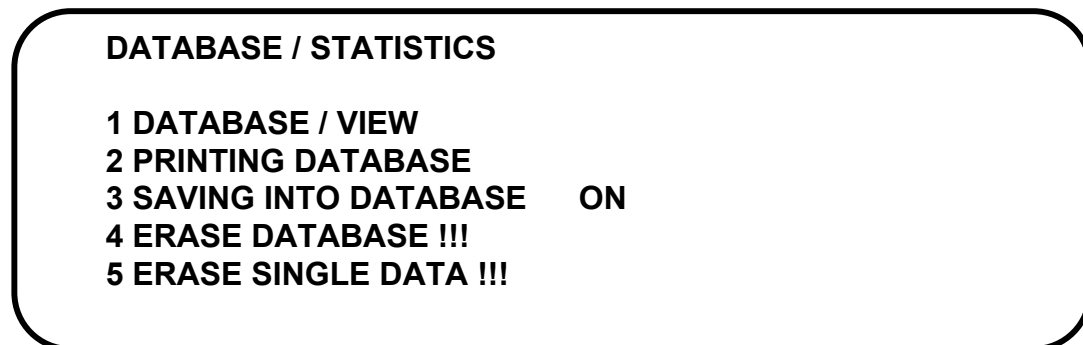

When **ENTER-key** is pressed all data will be deleted.

4.1.25 Setting Normal Range Value

In this menu point the **Normal range value** for each animal can be changed. If the value out of the range, the print out will be marked by “**”.

Display

SET NORMAL RANGE					
3.90	RBC	5.90	37.0	HCT	52.0
150	THR	300	0.015	PCT	0.035
4.0	WBC	10.0	27.0	MCH	32.0
12.0	HGB	17.0	32.0	MCHC	36.0
70	MCV	96	0	RCDW	15.0
7.2	MPV	35.0	0	LCDW	35.0

Notice: The normal control setting cannot be changed.

4.1.26 Select Parameters

In this menu, a desired function that was selected through the cursor can be turned on or off.

Display

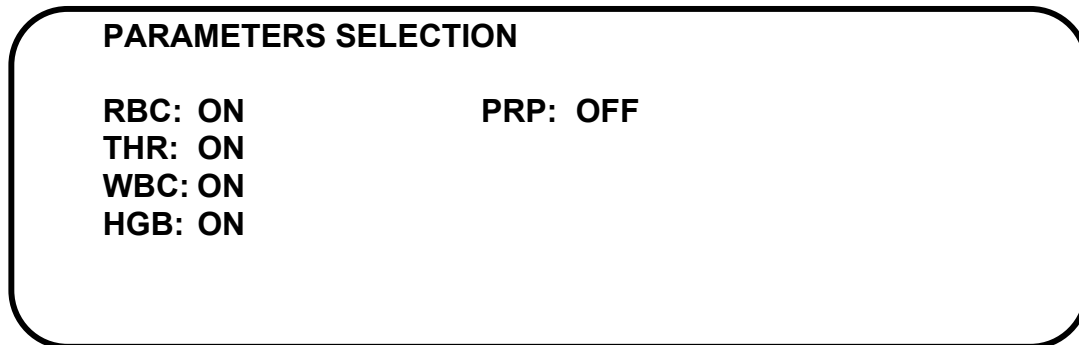

By pressing the **ENTER-key** the parameter can be selected.

When the entering is completed you can return to the main menu by pressing the **MODE-key**.

Alternatively, this is also possible by pressing the **START-key**.

4.1.27 PRP Blood

If this mode is switched on, all other measuring parameters are automatically switched off.

The PRP-mode is used to determine Platelets (Thrombozytes) from Platelet Rich Plasma (PRP) according to the Dextran T 500 method.
(check section "preparing samples")

4.1.28 RBC, THR/PLT, WBC, HGB

Any other parameters (measuring sectors) can be combined in open choice.

The calculated parameters that are correlated with the measured parameters are automatically switched on and off with the parameters that they depend on.

4.2 DILUTER FUNCTIONS

4.2.1 Filling the Diluter with lysing Reagent

This Bottom is needed to fill the tube system with lysing reagent, in case the supply bottle was empty.

The supply of the measuring system with lysing reagent is controlled. In case the system runs out of lysing reagent an alarm is given on the display. When the need of lysing reagent is signaled, replenish supply bottle.

Press **“F2”-key**.

The tube system is filled.
The process can be observed in channel **C2**.
If necessary, repeat procedure.

4.2.2 Filling the Diluter with Celloton

This Bottom is needed to fill the tube system with isotonic solution, if the supply bottle was empty.

The supply of the measuring system with **CELLOTON** (isotonic solution) is controlled. In case the **CELLOTON** supply is empty, it will be signaled on the display and the supply bottle must be replaced. After this was done the **“F2”-key** must be pushed and the diluting station and the tube system will be filled. The individual steps of the process can be watched in the status line.

Notice:

After installing a new supply bottle, in any case, a control measurement for all parameters should be made for a background determination. This way the user will become aware of a possible change in the quality of the isotonic solution that would influence results.

4.2.3 Taking into Operation

With this Bottom, the whole system can be cleaned and refilled with isotonic solution.

Usually, this is not necessary, if the system was switched off after going through **TAKING OUT OF OPERATION**, because then, if the instrument is switched on through the power switch, it puts itself into operation and the cleaning solution is automatically replaced by isotonic solution.

Press "**F3**"-key for manually using.

The supply of the measuring system with **CELLOTON** (isotonic solution) is controlled. When the lack of **CELLOTON** is indicated on the display, the supply bottle must be replaced.

When this is done, restart procedure. Again, the individual steps of the process can be watched in the status line.

4.2.4 Taking out of Operation

After the daily working routine, the whole system should be cleaned by activating the menu point **TAKING OUT OF OPERATION** before switching it off.

Press "**F4**"-key.

Cleaning solution is drawn from the cleaning solution container and the whole system is cleaned and refilled so that strong pollution are totally dissolved.

The individual steps of this procedure are indicated in the status line.

The supply of the measuring system with cleaning solution is controlled and the need of new supply is shown on the display. If this is the case the supply bottle should be replaced and the procedure be restarted.

If this mode is activated the sample tube should be also cleaned with **Celloclean^E**.

When this procedure is finished the display ask for this function.

Then instrument signals on the display that the system has put itself out of operation and asks to be turned off by switching off power.

4.2.5 Lysing Time

In case a different lysing reagent is used, it may become necessary to adjust the lysing time to the lysing reagent. This adjustment can be carried out through this menu point. The adjustable time reaches from 2 to 50 seconds.

Attention !

In case the lysing or hemoglobin reaction time is not adjusted, this can lead to wrong or unreproducible results and differential in the leukocytes or hemoglobin range.

4.2.6 Capillary Blood function

When the capillary-switch is pressed, a sample that was prepared manually can be processed. (check preparing samples)

Hold the AL-Cellcup underneath the needle for capillary blood.
By activating the micro switch, the extraction is automatically started.

After the extraction is finished, remove AL-Cellcup. The system now processes the sample and shows the results on the display or prints them out.

4.2.7 Dispenser function

When the dispense-switch is pressed, the Diluter prepare manually Celloton in a Cellcup.

Hold the AL-Cellcup underneath the needle for dispense.
By activating the micro switch, the dispense is automatically started.

After the dispense is finished, remove AL-Cellcup.
Now prepare the sample for capillary blood.

4.3 SYSTEM FUNCTION

4.3.1 Filling

During operation, bubbles in the volume unit cannot always be avoided.

The consequence would be a wrong measuring result.

This problem is recognized by the system and an automatic removal of the bubbles is tried.

In case the system does not succeed on its own an error report appears on the display and the system branches into an error menu. This way the user does not have to go through the main menu.

The whole measuring channel can be emptied and refilled completely by activating menu point "2" in "SYSTEM SETTING".

4.3.2 Cleaning

The system is equipped with a cleaning cycle that is sufficient for the normal use of the system.

In case of extreme soiling with defective solution or micro clots, which block up the capillary aperture, the cleaning cannot be executed automatically as the consequence of this would be a wrong measuring result.

If this occurs it is recognized by the system (shown on the display with the note "over time"). The system automatically branches to an error menu, so that you do not have to jump to the main menu.

By pushing the **NUMBER-key "3"**, a possible blocking of the capillary aperture is removed through pressure from the inside.

This function can be activated in the error menu as well as in the main menu

Attention !

Measuring solution is not usable afterwards as dilution ratio was changed.

4.4 Calibration

The results for all activated parameters can be adjusted here. Prerequisite is however, that a sample that was diluted with the diluting station was measured, and that the values were within normal range.

After having confirmed the selection by pushing the **ENTER-key**, the acceptable range of adjustment will be displayed in the status line.

The system will not accept entered numbers that are outside the displayed range.

Depending on what sample was last measured the blank values or the standard values can be calibrated.

4.5 Service

This menu is normally only used by a service engineer. However, there are some points that can be interesting for the user in order to check the system.

4.5.1 Calibration HGB

When this menu point is activated the automatic zero adjustment is switched off and the entered standard factors for the adjustment are put back on factory calibration.

The calibration can now be checked and if necessary the service engineer can undertake basic adjustments.

Attention !

If you should use this point a zero adjustment as well as a standard adjustment becomes necessary !

4.5.2 Factors

In this menu point the above mentioned carryover factors can be checked, changed or entered.

The factors that are to be changed can be activated by **NUMBER-keys** and **ENTER-key**. Now the number will be underlay and by the **NUMBER-keys** the required values can be entered. Press **ENTER-key** to confirm the change.

The values that are given in brackets are the standard factory calibrations.

By activating the menu point **DELETE CALIBRATIONS** all entered calibrations are set back to the standard factory calibration.

4.5.3 WBC-Settings

In this menu point the above mentioned WBC-settings can be checked, changed or entered.

The factors that are to be changed can be activated by **NUMBER-keys** and **ENTER-key**. Now the number will be underlay and by the **NUMBER-keys** the required values can be entered. Press **ENTER-key** to confirm the change.

The values that are given in brackets are the standard factory setting.

Attention !

If you change any point the WBC-adjustment becomes necessary !

Unproper usage will render the system unusable !

This point should only be entered by a service engineer.

4.5.4 Service Settings

In this menu point the measuring times of the **RBC- and WBC-channel** can be adjusted. This could become necessary when there were changes made on the vacuum system.

Also, further system actions that depend on exact time can be adjusted.

Attention !

Unproper usage will render the system unusable !

This point should only be entered by a service engineer.

4.5.5 Lyser Times

In this menu point the Lyser-amount can be adjusted by time.

This could become necessary when there were changes made for the Lyser or and three-part-diff settings.

Attention !

Unproper usage will render the system unusable !

This point should only be entered by a service engineer.

4.5.6 WBC Disc Settings

In this menu point the WBC-three-part-diff can be adjusted.

This could become necessary when there were changes made for the Lyser or and three-part-diff settings.

Attention !

Unproper usage will render the system unusable !

This point should only be entered by a service engineer.

4.5.7 Setting Time and Date

When this menu point is activated the time and date can be typed in.

Time / Date can be selected with up and down key. Confirm with **ENTER**.

Display

DATE / TIME

DATE: DD:MM:YY

TIME: HH:MM:SS

4.5.8 Diluter Info

In this menu point the diluter settings and maintenance information can be controlled. Waste amount and keyword can be adjusted or changed. This could become necessary when there were changes made on the system.

4.5.9 Reset Diluter

Electronic disturbances can cause a malfunction in the Diluter. By activating this menu point the Diluter goes through some working steps and is thus brought back to the starting position. If the Diluter has returned to its position the display signals "Ready for measurement" and the next sample can be processed.

Attention !

Unproper usage will render the system unusable !

This point should only be entered by a service engineer.

4.6 SYSTEM OPTIONS

Here, print mode settings and communication options can be chosen.

4.6.1 Automatic Print-out

By pressing **ENTER-key** the option can be switched **ON** or **OFF**.
If it is switched **on**, results will be automatically printed after the measurement.

4.6.2 Parallel port Print-out

By pressing **ENTER-key** the option can be switched **ON** or **OFF**.
If it is switched **ON**, you can select with the cursor keys two options.

4.6.2.1 Graphic Print-out

By setting with the **CURSOR-key** and confirming with the **ENTER-key** it is switched **ON**.

The results will be printed with distribution curves on the print out.

4.6.2.2 Ticket Print-out

By setting with the **CURSOR-key** and confirming with the **ENTER-key** it is switched **ON**.

The results will be printed without distributions curves.

4.6.3 RS 232 (no function - switch to off-)

By pressing **ENTER-key** the option can be switched **ON** or **OFF**.
If it is switched **ON**, you can select with the **CURSOR-keys** two options.

4.6.3.1 Printer Download (no function)

By setting with the **CURSOR-key** and confirming with the **ENTER-key** it is switched **ON**.

The results will be downloaded to a serial printer.

If you do **not use it** anymore, please, switch **OFF** to avoid disturbances.

4.6.3.2 Computer Download (no function)

By setting with the **CURSOR-key** and confirming with the **ENTER-key** it is switched **ON**.

The results will be downloaded to a serial computer port.

If you do **not use it** anymore, please, switch **OFF** to avoid disturbances.

4.6.4 Baud

By setting with the **CURSOR-key** and confirming with the **ENTER-key** it is switched **ON**.

In this case the baud rate can be changed to an standard baud rate step.

Note! Only when the correct rate is chosen the instruments work together.

4.6.5 SI - Units

By pressing **ENTER-key** the option can be switched **ON** or **OFF**.
If it is switched **ON** the results will be changed from **Standard-Units** to **SI-Units**.

4.6.6 HGB - Units

By pressing **ENTER-key** HGB-unit **GRAM** can be changed into **MOL-Units**.
This only will be provided when **SI-Units** are switched **on** .

4.6.7 Printer Paper-size

By pressing **ENTER-key** you can change the **paper size** from **11** to **12** inch.

4.6.8 Printer Emulation

By pressing **ENTER-key** the option can be switched **ON** or **OFF**.
If it is switched **ON**, you can select with the **CURSOR-keys** three options.

4.6.8.1 IBM Mode

By setting with the **CURSOR-key** and confirming with the **ENTER-key** it is switched **ON**.
The results will be printed out with the **IBM graphic mode**.

4.6.8.2 EPSON Mode

By setting with the **CURSOR-key** and confirming with the **ENTER-key** it is switched **ON**.
The results will be printed out with the **EPSON graphic mode**.

4.6.8.3 THERM Mode

By setting with the **CURSOR-key** and confirming with the **ENTER-key** it is switched **ON**.
The results will be printed out on the standard **printer**.

4.6.9 Auto Standby Mode

By pressing **ENTER-key** the option can be switched **ON** or **OFF**.

If it is switched **ON** the **auto standby mode** will be started after twenty minutes, when the instrument is in a waiting position.

4.6.10 Auto Cleaning Mode

By setting with the **CURSOR-key** and confirming with the **ENTER-key** it is switched **ON**.

If switched **ON** you can change the working rate by changing the numbers and the **auto cleaning mode** will be started after the adjusted amount of samples.

4.6.11 Blood saving mode

By pressing **ENTER-key** the system options can be switched **on** and **off** or selected line options.

If this menu point is activated the used blood volume will be reduced to a minimum.

Notice:

By using this option, the accuracy of the instrument might not be correct. For adjustment of the blood collecting, use transfer setting in the service options.

4.6.12 Three-Part-Diff-Mode

By pressing **ENTER-key** the system options can be switched **on** and **off** or selected line options.

If this menu point is activated the instrument use the three-part-diff-mode, the system use the fixed discriminator and threshold settings.

If the discriminator is zero, the diff-calculation will be off.

If the menu point is deactivated the system use the flooding point discriminator and threshold.

Notice:

If the settings for the Lyser, discriminator and thresholds is not correct the Three-Part-Diff results of the instrument is not correct!

4.7 What to do when the WBC-Sample-Needle is blocked?

Switch off the instrument
Remove the cover (front side)

Remove the tube from the nipple (2) or needle (4)

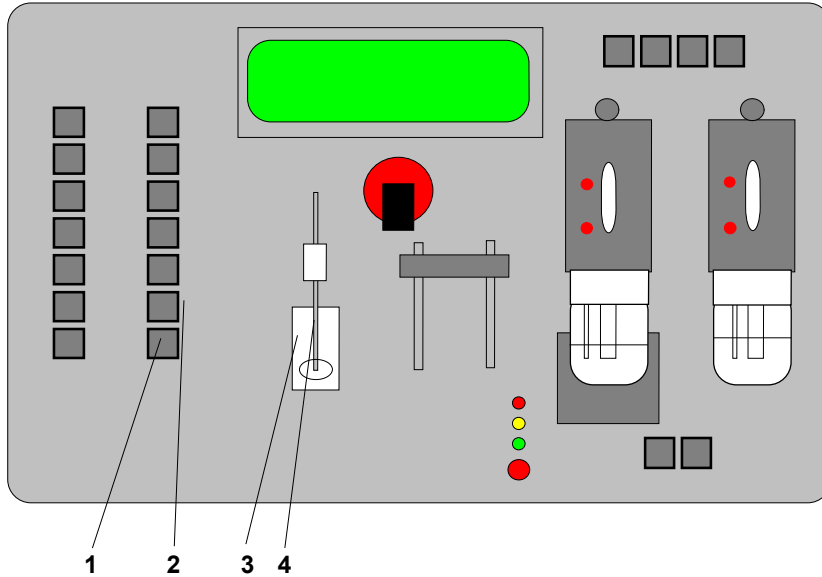

Remove the tube from the valve nipple (1) or clean plate (3)

Take a syringe and clean the tube. Push the Valve manually if is necessary.

4.8 What to do when the RBC- Sample-Tube is blocked?

Switch off the instrument
Remove the cover (front side)

Remove the tube from the nipple (2) and the RBC-sample valve (1)

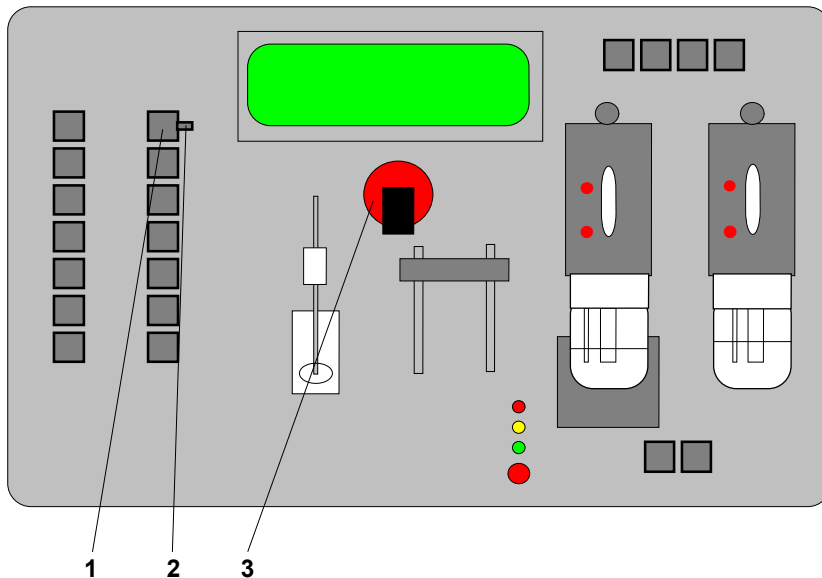

Take a syringe (3) filled with **CELLOCLEAN^E** and fix it on the tube (4).

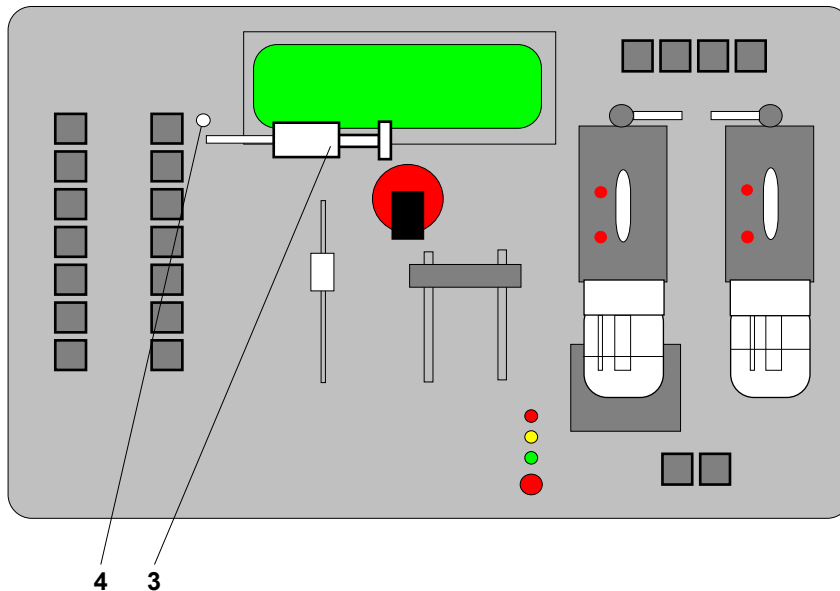

Clean the tube with **CELLOCLEAN^E** by pushing and pulling.
Insert the tube of the RBC-valve (1) and connect the tube (4) with the nipple (2).
Check the RBC-valve (3), by removing the cap (if necessary).

Fix the front-cover of the instrument.
Switch on the instrument and carry out a blank solution.

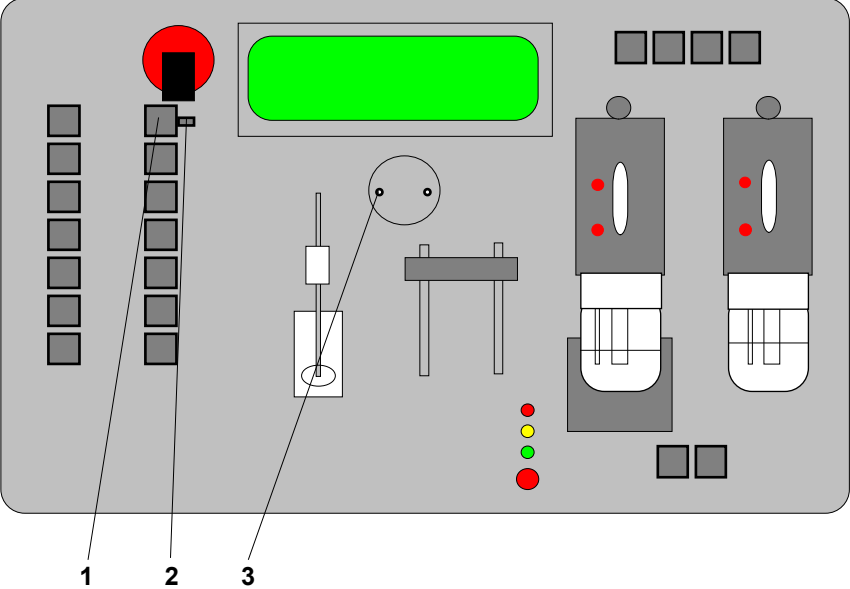

4.9 What to do if the WBC-Capillary is blocked ?

Use auto-cleaning -**pressure only**- or -**complete cleaning**- or

Manually-cleaning:

If the pressure of the built-in pump is not strong enough to remove extreme blockages, remove capillary and clean it manually.

Use a (10 ml)syringe filled up with **Celloclean^E** and connect it with tube (rubber).

By pushing and pulling with the piston of the syringe the blockage can be removed.

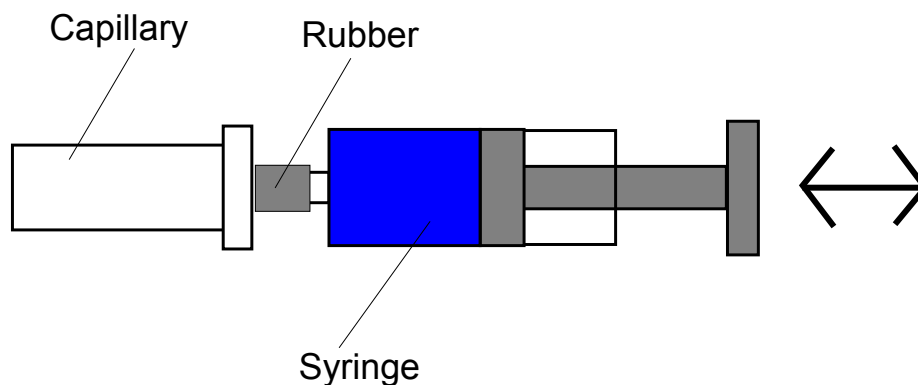

Remove the syringe and fix the capillary in original position.
Then carry out a blank measurement.
If the measuring time is correct, fix front cover.

Note:

The replacement of the WBC-capillary always makes a check of the HGB-adjustment necessary.

Solution-cleaning:

If the capillary is not blocked completely, the following steps can be done:

Fill ca. 6.0 ml **Celloclean^E** in an **Cellcup**.

Hold the **Cellcup** underneath the needle for capillary blood.

By activating the micro switch, the extraction is automatically started.

After the extraction is finished, remove **Cellcup**.

The system now processes the solution.

Wait for one or two minutes and start some manually measurement.

The capillary will be cleaned by measuring.

Then carry out a blank measurement.

4.10 What to do if the RBC-Capillary is blocked ?

Use auto-cleaning **-pressure only-** or **-complete cleaning-** or

Manually-cleaning:

If the pressure of the built-in pump is not strong enough to remove extreme blockages remove Capillary and clean it manually.

Use a (10 ml)syringe filled up with **Celloclean^E** and connect it with tube (rubber).

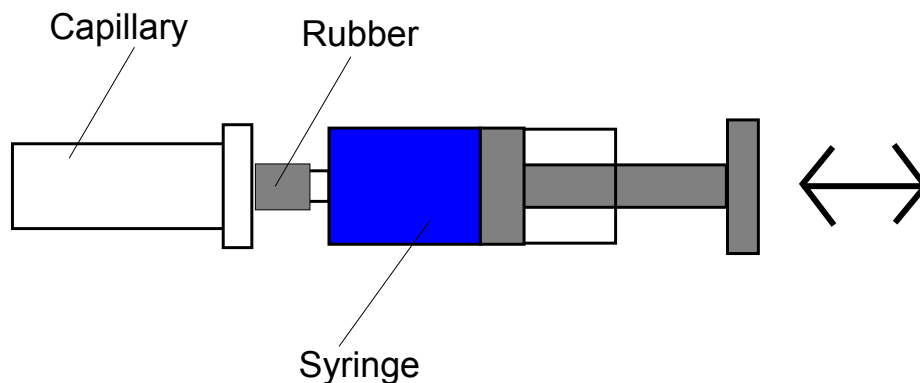

By pushing and pulling with the piston of the syringe the blockage can be removed.

Remove the syringe and fix the capillary in original position.

Then carry out a blank measurement.

If the measuring time is correct, fix front cover.

Solution-cleaning:

If the capillary is not blocked completely, the following steps can be done:

Remove the RBC-Measuring-Chamber and fill it with **Celloclean^E**.

Now place the RBC-Measuring-Chamber in his original position.

Press **Start-Button**, the system now processes the solution.

Wait for one or two minutes and start some manually measurement.

The capillary will be cleaned by measuring.

Then carry out a blank measurement.

5 MEASURING WITH THE SYSTEM

6.1 DETERMINATION OF RBC, WBC, HGB, THR/PLT

5.1.1 Required Materials

Apart from the measuring instrument, the following equipment is required for measuring RBC, THR, WBC, and HGB.

- | | |
|---|-------------------------|
| - Diluting Solution | Celloton-diff. |
| - Hemolysis Reagent | Autolyse-diff. |
| - Dilution Container | Cups* |
| - Cleaning Solution | Celloclean ^E |
| - Stand for Samples | Sample Rack* |
| - EDTA - Tubes 4 ml or 20µl Capillaries | |
| - Sample-Mixer | |

For samples we recommend venous blood, which contains **K-EDTA** as blood clotting inhibitor.

* only for capillary method

5.2 PREPARATION OF THE SAMPLE

The well-mixed blood, which was prepared on the mixer, is processed as follows:

5.2.1 Primary-Dilution - WBC (LEUKOCYTES)

By pressing the sample button or activating the light barrier, the blood is taken from the sample needle and the system absorbs 20 µl EDTA-blood.
20 µl blood is diluted with 6,0 ml **Celloton** and transferred into the mixing chamber (dilution 1 : 300),
alternatively
mix 20 µl capillary blood with 6,0 ml of isotonic solution for capillary blood.
After the secondary solution is drawn 0,6 ml lysing reagent is added during the transfer into the WBC-Measuring-chamber

5.2.2 Secondary-Dilution - RBC (Erythrocytes)

The dilutor absorb 20 µl suspension from the mixing chamber (WBC-dilution) and dilutes with 3.0 ml **Celloton**.
Then it is transferred into the RBC-mixing-chamber (Dilution referred to EDTA-Blood 1 : 45.000)

Important for three-part-diff !

Use only adapted lysing reagent for the instrument.

Use the correct lysing time.

!! Otherwise a three-part-differential cannot be detected !!

5.2.3 Capillary Blood Dilution

Dispense 6.0 ml **CELLOTON** with System-Diluter into an AL-cup and add 20 µl capillary blood.

Dilution ratio 1 : 300

With the AL cup activate the micro switch on capillary-blood-needle and suck in the complete solution.

After removing the sample cup the diluting circle will be started.

5.3 COUNTING OF PLATELETS WITH THR/PLT-ANALYSER

5.3.1 Determination of Platelets from Whole Blood

The **AL-Hematology-VetSystem** is suited for the determination of platelets from whole blood simultaneously with the RBC-measurement through the use of a THR/PLT-Analyser.

Through a microcomputer the platelets are automatically determined and evaluated parallel to the RBC-measurement.

However, it has to be noted that with this method not the same precision can be reached as with the PRP-method.

Also, the instrument does not give a specification about the condition of the determined cells, so that with very pathologic cells or extreme concentrations, a faulty determination by the computer might become possible.

However, this is recognized by the computer and an alarm is given with an error-report on the display.

The evaluation-error outside of the normal measuring range of 150-400.000 platelets/ μ l may be more than 20%.

In extreme cases the PRP-Dextran-method should be used.

Attention !

In case various control substances are used, it has to be taken into consideration that not every control blood is suitable to be analyzed with the analyzer, because the discriminators and the analyzing criteria are adjusted for human-blood.

This particularly applies to abnormal blood.

Because of this, it has to be guaranteed that the control-blood does not contain any latex particles and that it corresponds to human blood. Due to their different contents, the various control-bloods can have different results.

It is important that the measured values are correct for human-blood rather than for control-blood that have non-human particles.

5.3.2 Measuring Range with THR/PLT-Analyzer

When THR concentrations of less than 100.000 are measured an error of more than 20 % can occur due to the dependency on RBC.

With THR values of more than 350.000 a difference compared to other measuring methods can occur. A possible error of more than 30 % is due to the dependency on RBC.

Of course, the system also determines values of platelets that are far below or above these values and are still precise.

However, the values mentioned above are given to emphasize the sensitivity of the method and are meant to help you to avoid improper use of the system and of certain values

ANALYSING RANGE : 3 - 25 fl

NORMAL RANGE : 2 - 35 fl

Attention!

Remember that very small particles are not analyzed. In that case the result is normally marked with "I", "L" or "R".

5.3.3 Determination of Blank Values

For the exactness of the measurement it is important to use isotonic solution of high quality in order to have lowest possible blank values.

If this is not the case, results in the pathological range can be distorted or even be unusable.

Determine blank values of the solution by some measurements without blood. The blank value must be below 50. When the blank value is acceptable blood samples can be measured.

In case of extremely low Thrombocytes, the blank value - particularly when it is above 10 - has to be taken into consideration for a correct result.

For example:

Sample	Value	80
Solution	Blank value	-15

Sample value = Measuring result 65

5.4 THE DISPLAY OF THE PLATELET DISTRIBUTION

The THR-histogram can be called up at any time, after the measurement is finished, by pressing the **CURVE-key**.

If extremely pathological results are measured an error report with the platelet distribution curve will automatically appear on the display so that the user can decide himself whether the measured result is acceptable or not.

5.4.1 The standardized Distribution Curve

The following display shows a standardized THR-distribution curve. The numbers 1 to 5 explain the position of the different evaluation parameters.

The common way of displaying the distribution curve is the standardized curve.

Display

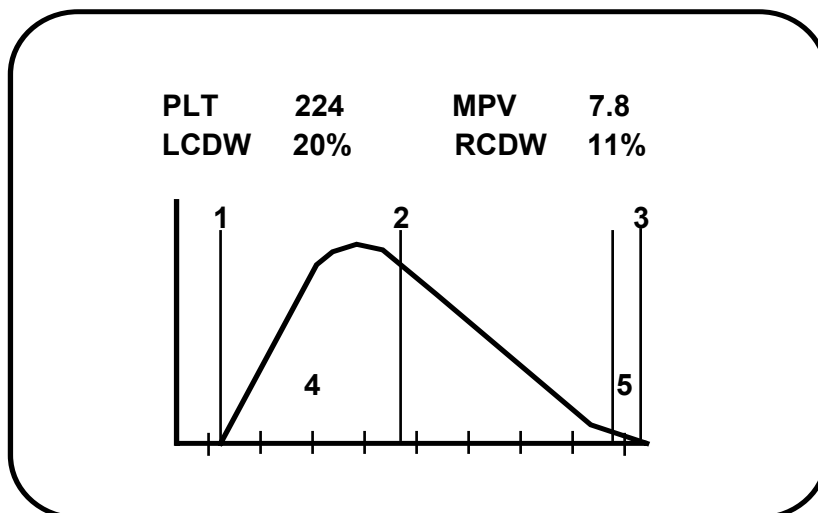

1 = lower discriminator

2 = MPV

3 = upper discriminator

4 = LCDW 5 = RCDW

As the standardized curve does not show the background noise, the curve is distorted or even falsified, particularly with low values. The transition of THR/PLT distribution and of electronic noise can not be controlled visually. Thus, the recognition of a loss of very small platelets or of electronic disturbances of the measuring system depends entirely on the evaluation criteria of the computer.

Therefore, MDC refrained from giving a standardized distribution curve.

5.4.2 The not-standardized Distribution Curve

The advantage of this type of curve is that it corresponds to the original measurement of the THR-distribution. Parts of the electronic noise (6) are also displayed so that a judgment on whether there is an interference because of disturbances or very small particles becomes easy.

Display

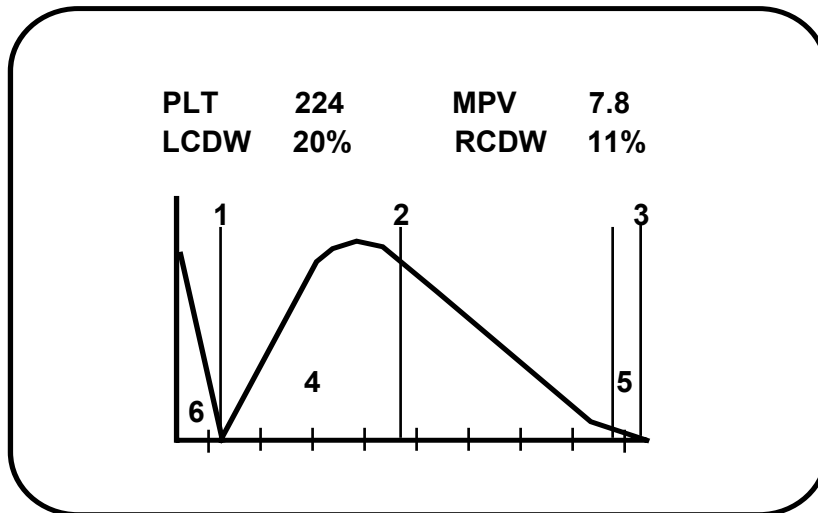

1 = lower discriminator

2 = MPV

3 = upper discriminator

4 = LCDW

5 = RCDW

6 = Electronic noise

It is possible that the display of the platelet distribution curve differs to some extent from the standard curve, even if the measurement was correct.

The appearance of the curve depends on the total number of particles as well as on the particle size.

If errors occur that are recognized by the system, the appearances of the curves differ as follows:

5.5 ERROR INDICATIONS WITH THR/PLT-ANALYSER

5.5.1 Results marked with "L" = LCDW

Display

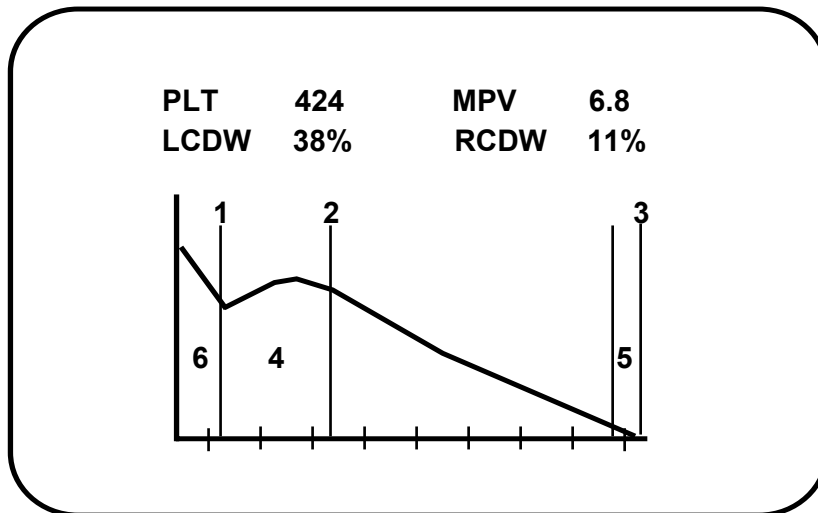

1 = lower discriminator
3 = upper discriminator
5 = RCDW

2 = MPV
4 = LCDW
6 = Electronic noise

The distribution of platelets does not correspond with an acceptable standard distribution. The number of the counted platelets on the left control sector exceeds 30 % . (the normal range is 0 - 30 %).

The cause for this can be pollution, electronic interference that merge with the background noise, or destroyed RBC's and cellular debris that distort the measuring result.

5.5.1.1 Normal or extremely high values that are marked with "L" or "I"

The result can only be used with restrictions. Check the usability of the result by the histogram and the LCDW value !

Clean the system and determine the blank value once or twice to check the system.

Then measure the sample again. If the result is still marked again with "L" or "I", the distribution values are abnormal.

A look at the distribution curve will then allow a judgment on whether or not the results can be used.

If the blank values are not o.k.

Replace capillary and measure another blank solution.

If no acceptable blank value can be reached, the reason could be a defect in the system or an unsuitable quality of the isotonic solution.

5.5.1.2 Low value marked with "L" = LCDW

The criteria of measuring evaluation were set up for a normal platelet distribution. When a very low concentration of platelets is measured, it is possible that the system gives an error report because the distribution is shifted to values of more than 30 % on the left.

A check of the distribution curve can tell whether the result can be used or whether there is a disturbance.

If the electronic noise is not clearly separated from the platelets, rinse the system and determine the blank value.

If the blank value is o.k. repeat the measurement.

Attention !

If the system continues to give error reports, the reason could be extremely small platelets.

If in doubt, always check the result through an equivalent method.

5.5.2 Results marked with "R" = RCDW

Display

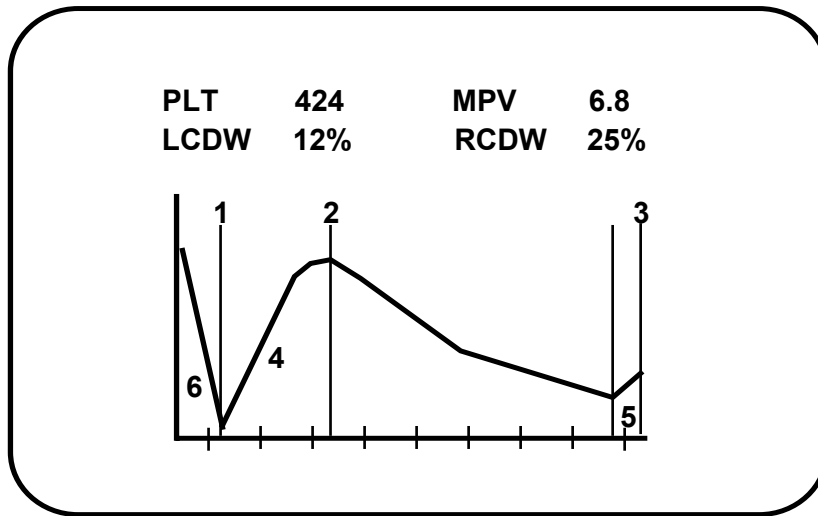

1 = lower discriminator

2 = MPV

3 = upper discriminator

4 = LCDW

5 = RCDW

6 = Electronic noise

A platelet distribution curve appears on which more than 15 % of all counted platelets were found in the control sector between Thrombocytes and erythrocytes. The possible cause can be abnormally big Thrombocytes or an erythrocyte-interference by very small erythrocytes.

Attention !

If in doubt, always check result through an equivalent method.

5.5.3 Results marked with "M" = MPV-Alarm

Display

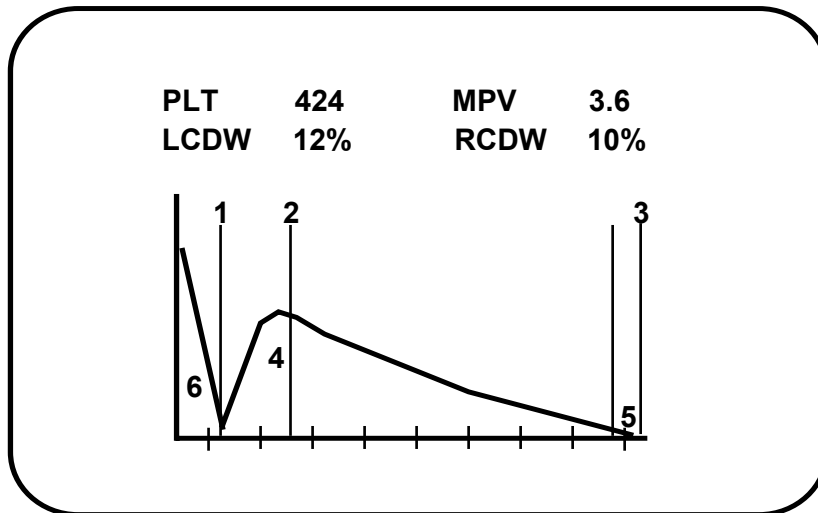

1 = lower discriminator

2 = MPV

3 = upper discriminator

4 = LCDW

5 = RCDW

6 = Electronic noise

The distribution is normal but the average platelet volume (MPV-value) is smaller than 4,5 fl.

This means that, although the distribution of platelets is correct, the MPV is shifted to the left and the LCDW warning cannot react because the deviation in the distribution is less than 30 %.

Attention !

If in doubt always check result through an equivalent method.

5.6 RECOGNIZING ERRORS THROUGH THE HISTOGRAM

Errors or disturbances in the measuring cycle will influence the histogram. With some experience the cause of the disturbance can be recognized by studying the distribution curve.

5.6.1 System Error - LCDW

The distribution curve shows disturbances of the measurement on the left side. The appearance of the curve can differ more or less, depending on the cause of the disturbance.

Display

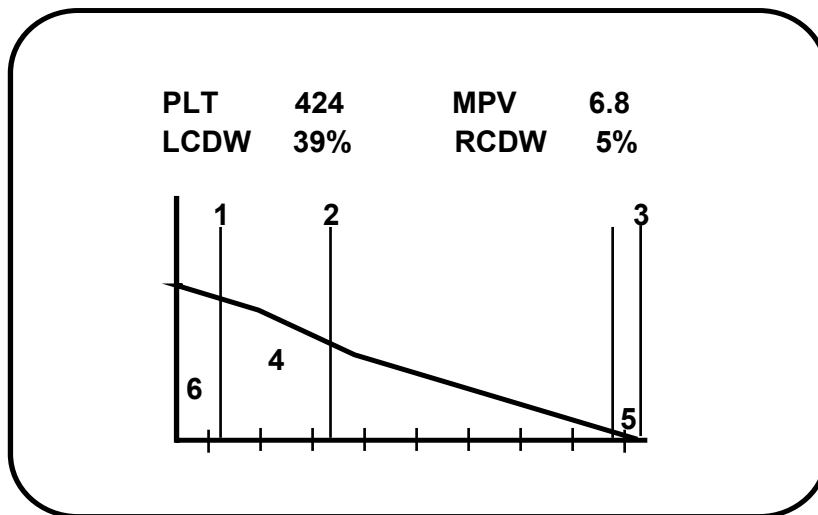

1 = lower discriminator 2 = MPV
3 = upper discriminator 4 = LCDW
5 = RCDW 6 = Electronic noise

Possible causes are :

- Pollution of the capillary by particles or cleaning solution.
- Short-time blockage of the capillary aperture by a micro-clot or a bit of fluff.
- Electronic noise is too high.
- Capillary is defective, short-circuits are caused by cracks in the glass.
- Measuring solution is defective.

5.6.2 System Error - RCDW

The distribution curve shows disturbances in the measurement on the right side. The appearance of the curve can deviate depending on the cause of the disturbance.

Display

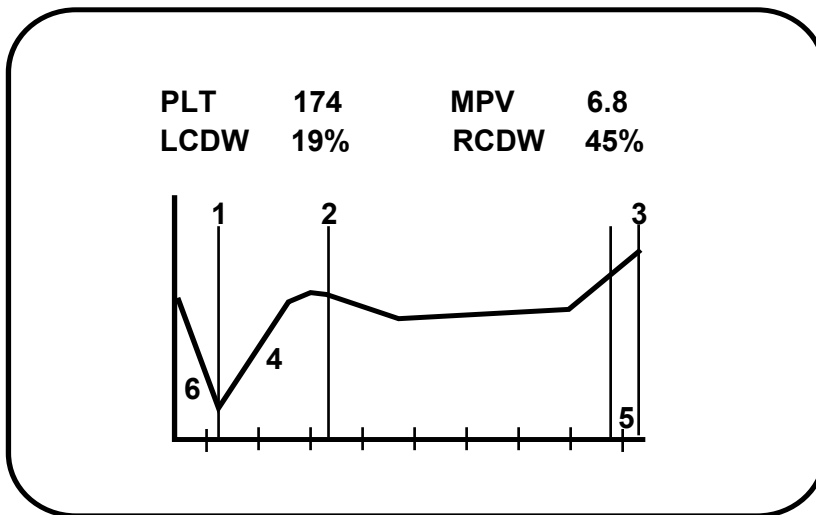

1 = lower discriminator
3 = upper discriminator
5 = RCDW

2 = MPV
4 = LCDW
6 = Electronic noise

Possible causes are :

- Defective capillary, short-circuits through cracks in the ruby or plastic.
- Defective isotonic solution.
- Defective capillary aperture, possibly worn.
- Measuring sample defective, interference of erythrocytes (RBC)
- Electronic defect, capillary tension too low.

5.6.3 System Error - " ? " or "00"

The distribution curve shows disturbances of the measurement about in the middle and the result is marked with " ? " or the result is " 00 ".

The course of the curve can be higher or lower, depending on the cause of the disturbance.

Display

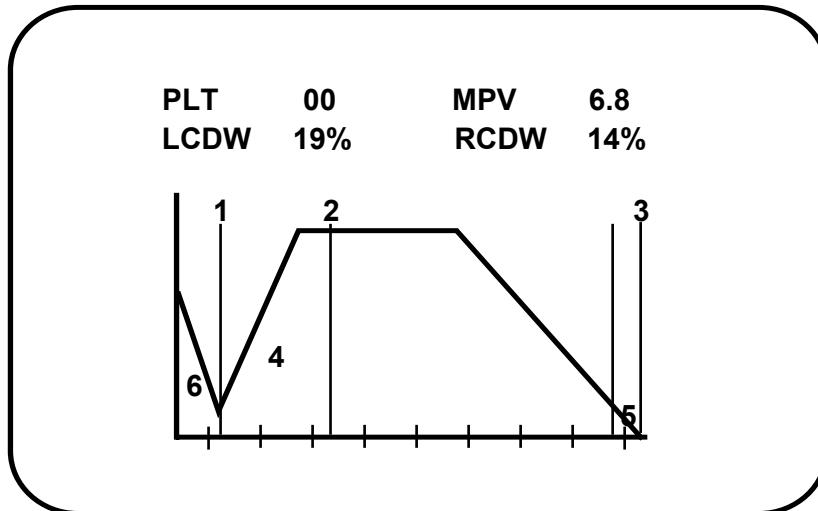

- | | |
|-------------------------|----------------------|
| 1 = lower discriminator | 2 = MPV |
| 3 = upper discriminator | 4 = LCDW |
| 5 = RCDW | 6 = Electronic noise |

Possible causes are :

- Overflow of the distribution curve because of too high measuring results.
- Sample is too high, dilution must be checked.
- Measuring solution defective.
- Capillary aperture defective, possibly worn.
- Measuring sample defective.
- Electronic defect, analyzer card does not work properly.

5.7 THE DISPLAY OF THE RBC-DISTRIBUTION

The distribution of the RBC-curve presently has no diagnostic value and serves only for the checking of the particle distribution (e.g. THR/PLT interference and for checking the MCV-value).

Display

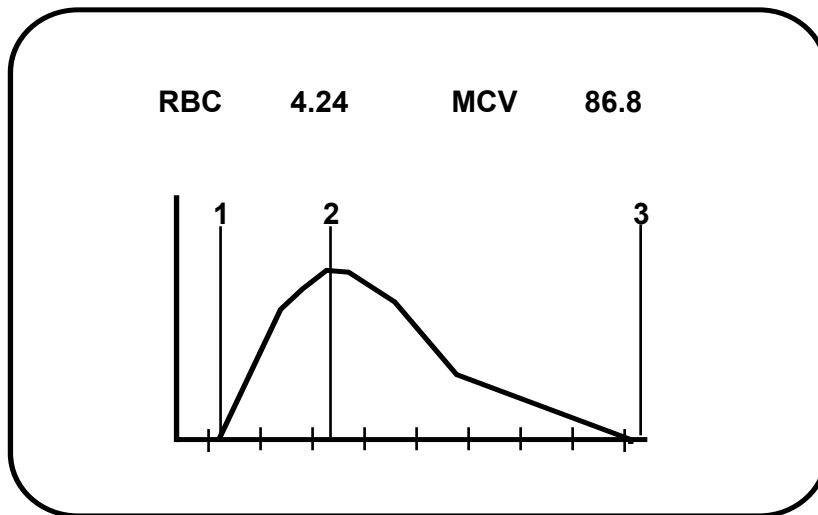

1 = lower discriminator
3 = upper discriminator

2 = MCV

5.8 THE DISPLAY OF THE WBC-DISTRIBUTION

The distribution of the **WBC-curve** is needed for checking the particle distribution to calculate **LYMPHOCYTES**, **GRANOLOCYTES** and **MIDS**.

Display

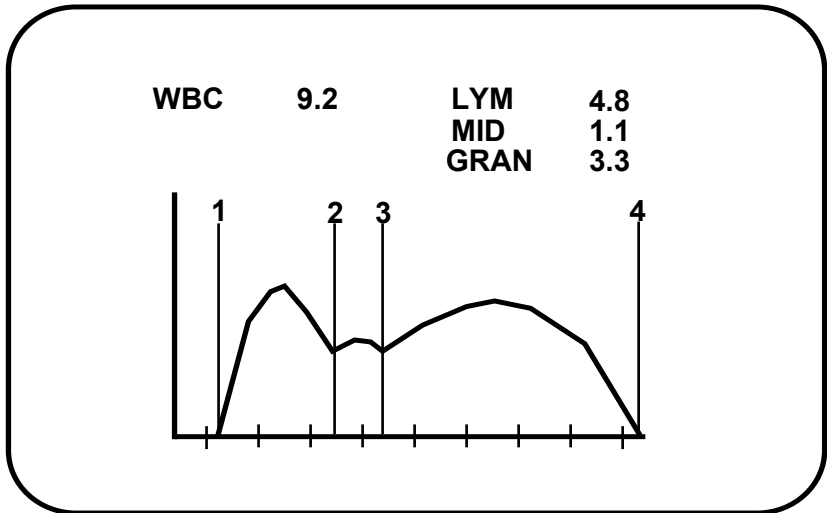

1 = lower discriminator 2 = middle discriminator 1
3 = upper discriminator 2 4 = upper discriminator

5.8.1 Setting WBC - Discriminator

The results of **Lymphocytes**, **Granulocytes** and **Mids** will be automatically, when the distribution of the WBC-curve is clear.

However if necessary the result can be changed by moving the discriminator.

Choose single picture display with the **ARROW-key** up.

When the WBC-distribution appears on the display, press **ENTER-key**.

Display

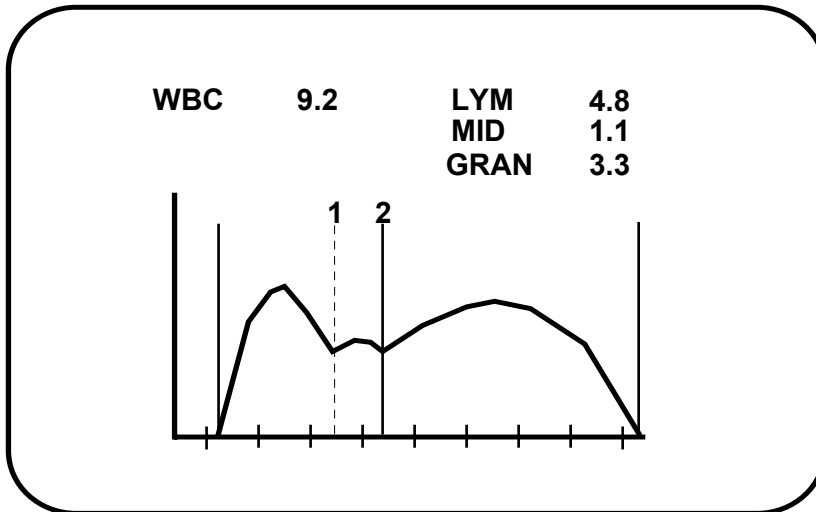

Use **CURSOR-key up and down** to move the discriminator 1.

If the discriminator is in the right position press **ENTER-key** again.

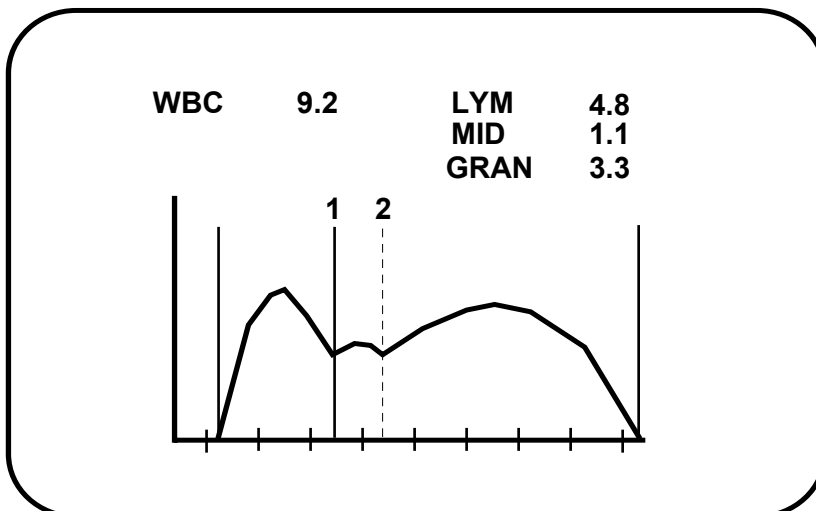

Use **CURSOR-key up and down** to move the discriminator 2.

If the discriminator is in the right position press **ENTER-key** again.

The result will be calculated new.

5.9 PLATELETS BY PRP-DEXTRAN-METHOD

5.9.1 In General

The **Hematology-VetSystem** is generally suited for counting the Thrombocytes from Dextran solution.

Because of corresponding window-discriminators it can be guaranteed, that only particles the size of the Thrombocytes are counted.

Larger particles exceed the higher threshold-value and are not counted.

Attention !

This method is very sensitive. Absolute cleanliness is prerequisite as well as completely particle-free solutions and materials.

5.9.2 Process-Description

The EDTA-Blood is diluted with a Dextran solution which has a high molecular weight. Dextran causes the coagulation of the erythrocytes. They are then separated by an appropriate centrifugation.

Thrombocytes are left over in the solution and keep floating for quite some time in the solution because of their specific gravity.

5.9.3 Required additional Materials

Diluting Solution

Thrombocent

Centrifuge-tubes (for example Eppendorf-tubes)

Thrombocyte Centrifuge

Attention ! The use of EDTA blood samples is recommended !

5.9.4 Preparation of Samples

Dilute 60 µl of well mixed EDTA-Blood with 1.5 ml (1 : 25) of Thrombocent in a Thrombo-tube or Eppendorf-tube.

Mix this dilution shortly and let it stand for 5 min.

Thereafter, put the Thrombo-tubes into the Thrombo-centrifuge and centrifuge the diluted samples for 3-5 min.

After completion of the centrifugation, take from the middle of the solution with the sample needle by pushing the sample bottom.

Now you have the Measuring Solution.

Attention !

Please avoid squirting the dilution into the cup, so that the sensitive Thrombocytes will not be destroyed. Best, if you slant the cup slightly.

Only use a centrifuge with 900 R/Min with 100 g because otherwise the measured solution will not correspond to the actual platelet number and the result will be unusable.

5.9.5 Handling of the Instrument

Menu point **PRP ON** (all other parameters off)

For background measurement, determine blank solution by measuring **CELLOTON**.

It is possible, that a low blank-value is not attainable because of a possible contamination of the measuring solution or of possible pollution at the aperture-tube. In this case repeat the measurement with fresh blank solution until a blank value not exceeding 025-030 is reached. If necessary, check aperture-tube and solution.

When the blank value is acceptable the sample can be measured.

In case of extremely low Thrombocytes, the blank value has to be taken into consideration for a correct result, for example:

Sample	Value	80
Solution	Blank value	-15

Sample value = Measuring result 65

Attention !

**The instrument must only be checked with control substance for pure Platelets-control that does not contain any erythrocytes (RBC).
If centrifuged control-blood or control-blood with Latex-particles is used you will receive wrong results !!**

Different control substances can lead to different results depending on the particles used.

The system is adjusted on human-platelets.

The measured values should not necessarily correspond to control-blood but rather to measured human-blood.

Note!

The calibration of the instrument is made for whole blood.

For PRP-method the first calibration must be changed to the corresponding result.

5.10 REQUIRED MATERIALS AND REAGENTS

To operate the instrument, high quality solutions and disposable materials are required, which are guaranteed to be particle-free and always of the same quality.

When in doubt, always use the original **AL-Accessories**.

In the following, you will find names and order numbers as well as packing amounts of all **AL-Accessories**.

ARTICLE	NAME	USING	PACK SIZE
78311	Celloton-diff.	Diluting solution	1x20 l
78310	Autolyse-diff.	Lysing / HGB-Reagent	5 l
77664	Cellcups	Particle free Cups	1.800 pcs*
78415	Celloclean ^E	Cleaning Solution	3x500 ml

The following reagents / equipment is only needed for the determination of THR by PRP-method.

Thrombo-Centrifuge for THR separation.

ThrombocentThrombocytes Reagent

Thrombocups Particle-free Cups

* only for capillary method

5.11 WORKING WITH VENOUS- AND CAPILLARY-BLOOD

5.11.1 Extraction of Samples

The quality of the available blood is of great importance. Please let us give some advice on this.

AL-Hematology-Systems are suited for the processing of venous blood or capillary blood.

5.11.2 Venous Extraction (EDTA-Blood)

Required are: EDTA coated tubes
 70% Ethanol
 Sterile cannula

After puncturing the vein, let a few ml of blood flow into the EDTA-tube. This is sealed with the stopper and is then carefully turned over several times (swaying) to enable the anticoagulant to thoroughly dissolve and mix with the blood. However, shaking and foaming has to be avoided absolutely .

Advantages:

Easy further processing of the sample is possible.

No mistake on the volume values because is possible of tissue fluid.

The EDTA blood will keep for 24 hrs. in a sealed tube at room temperature.

Enough sample material for numerous classifications is available.

5.11.3 Capillary-Blood

Required are:

Capillary 20 μ l
Swabs, sterile lancets
70% Ethanol
Cellcups

It is important that before extracting capillary-blood, particularly with anemic patients and patients with low skin temperature, the pad of the finger should be hyperaemicised by rubbing or by warming in warm water.

Rub the pad of the finger well with Ethanol (preferably the ring finger of the left hand) and prick the finger 2-3 mm with a sterile lancet.

Wipe away the first drop of blood with a swab and then take the spontaneous flowing blood to fill the capillary.

Disadvantages and Sources of Error:

Please avoid squeezing and pressing of the finger after pricking. This causes tissue fluid to be mixed with the blood, which can cause a volume error of up to 15%.

5.12 DILUTION RATIOS

The AL-Hematology-Instruments work at an **end-diluting-ratio** of:

WBC 1 : 300/350
RBC 1 : 45.000

Primary dilution:

WBC, HGB

20 µl EDTA-blood + 6.0 ml CELLOTON and 0.6 ml Lyse

Secondary dilution:

RBC, HCT, MCV, THR/PLT

20 µl primary dilution + 3.0 ml CELLOTON

Note !

The sample tube of the diluter must be carefully freed from all external remains with a fluff-free cloth.

5.12.1 Stability of the samples

The stability of the samples is dependent on different factors. The data below refer to the capillary-blood method and are not transformable to the automatic system.

Primary dilution	: ca. 4 hours (room temperature)
THR/PLT primary dilution	: ca. 2 hours
THR/PLT secondary dilution	: ca. 15-20 minutes

Notice

The primary dilution should be mixed up smoothly after a long standing period before it is diluted.

Please, use a fluff-free cloth to clean the suck-in tube of the Diluter in order to avoid that particles of cellulose will spoil the sample what leads to a blockage of the capillary.

5.12.2 Dilution-steps

Dilution for measuring WBC

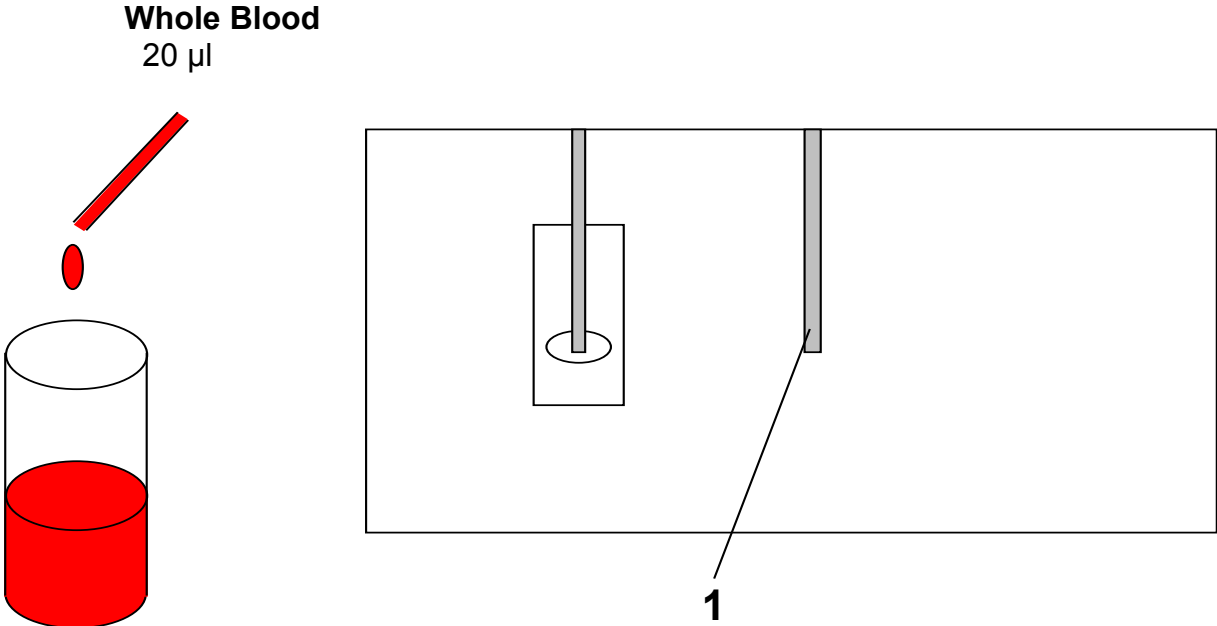

Dilution has to be sucked in completely by **capillary-blood tube (1)** by activating the micro switch and will be measured.

5.12.3 Errors which often occurs

Most of the disorders in measurement and result are avoidable.
Therefore, please accept the following advice:

- Always use fresh blood.**
- Avoid squeezing and pressing of the finger when taking capillary extractions.**
- Use tested solutions and particle-free one-way material.**

Most errors are caused by partial or complete blockage of the capillary aperture.

Other causes are:

- particle polluted sample containers**
- pollution of the reagents**
- pollution caused by unsuitable cloths**
- unclean aids (pipettes a.s.o.)**

Further problems are caused by the incorrect wiping of the suction sonde and consequently inaccurate dilutions.

Please remember that the material that is measured is available in quantities of μl range.

Most electronic and mechanical disorders are recognized by the

AL-Hematology-System.

This is vital for the correctness of the measuring results.

The following disturbances may occur:

- the aperture-tube is blocked partly or completely**
- bubbles are in the fluid system**
- measuring unit is polluted**
- instrument needs a follow-up calibration**
- wrong dilution has been measured (cap. method)**

6 MAINTENANCE

6.1 DAILY CONTROLS

The **AL-Hematology-VetSystem** controls the waste and supply bottles as well as the system pressure. But it is still important in order to avoid disruptions to include the following points into the routine.

Check the waste bottles daily and empty them if necessary.

Check the supply bottles and replace or fill them if necessary.

Notice :

Discard the left-overs in the supply bottle, so that new supplies are not polluted by possible spoiled left-overs.

Attention !

As the system works with pressure and vacuum and the pressure sensors do not indicate small pressure leaks it is very important that the waste and supply bottles are always closed correctly.

If the system is not used for a longer while switch off the instrument after it has gone through **TAKING OUT OF OPERATION**.
This way the system will be automatically cleaned.

6.1.1 The Capillaries

The capillaries must always be covered by isotonic solution or by enzymatic cleaning solution **CELLOCLEAN^E**.

The capillary must not be dried unless it was carefully rinsed with distilled water.

Before switching off the system cleaning reagent must be used always.

6.1.2 The HGB/WBC-Chamber

As a principle before each longer interruption of the measuring routine a blank solution should be measured or the system should be put into the standby mode. (compare standby-mode)

Clean the HGB-cuvette after the measuring routine by using the menu point **TAKING OUT OF OPERATION**.

6.1.3 Error Reports

A microprocessor controls the system and optical and pressure sensors are applied to check the fluids so that major errors are detected by the system and reported on the display.

However, the adjustment of the sensors allows the system to accept minor variations in pressure in order to avoid frequent, unnecessary error reports.

When a waste bottle is not properly closed or the seal is defective it can cause a partial loss of pressure that is not recognized by the system.

This error report must then only be taken as a hint and does not correspond with the true cause of the error report, as normally not both capillary apertures become polluted at the same time.

The waste bottles are controlled by photo-optical sensors to prevent overfilling. If the fluid-level reaches a critical point the sensor will react and a warning will be displayed on the display.

Notice:

In this case the waste bottles must be emptied.

Attention !

An overfilling of the waste bottles can cause the destruction of the vacuum pump!

Notice:

When the system alarm was activated to warn of full waste bottles it is possible that because of some water drops the system will still warn of full waste bottles even after they were emptied.

If such an error report should occur and you are sure that the waste bottles are empty, press the ENTER-key.

The alarm display will now be deleted and you can continue to work.

6.2 WEEKLY MAINTENANCE

6.2.1 Aperture-tube

To enable the equipment to run free of disturbances, the aperture-tube must be kept in good condition. In the surrounding of the capillary aperture and in the aperture tube itself protein deposits can occur, especially when counting white blood corpuscles.

The following guidelines are to be kept:

never let the aperture-tube dry out.

never let the aperture-tube stand in a blood sample for too long.

rinse the system well with CELLOTON and cleaning solution between work phases or when the Cellcounter is not going to be used for a longer period of time.

inspect the aperture-tube regularly under a microscope with a 10 x enlargement for deposits or cracks in the glass around the sapphire.

Cleaning of the aperture-tube:

Depending on the amount of samples, the capillary should be replaced and cleaned weekly. For cleaning, the aperture-tube is emptied and put into fresh **CELLOCLEAN^E**, so that the inside of the capillary is filled with the cleaning solution through the aperture. This way the aperture opening is rinsed and freed of albumin deposit.

The Cellcounter is furnished with one aperture-tube for each measuring channel. However to be safe, spare aperture-tubes should always be at hand. When the Cellcounter is not used for some time, the tube has to be cleaned in **CELLOCLEAN^E** and rinsed with aqua-dest.

IMPORTANT !

The Cellcounter must never be rinsed with bleaching substances (alcohol) or other synthetic cleaning solutions.

Never use a cleaning device that uses ultrasonic waves as this would cause cracks and destroy the capillary-tube.

Notice:

For cleaning the aperture-tube from extreme dirt, Dichromate-Sulfuric-Acid can be used, but only outside of the system.

6.2.2 Measuring and Volume Unit

This part is to be inspected occasionally by opening the front cover of the instrument.

The inside walls of the volume tubes must not show any signs of stains or deposits.

Notice :

In extreme cases the cap can be removed and the glass-tube cleaned with a small tube brush or a pipe-cleaning brush.

The formation of deposits can be avoided to a large extent by using an appropriate cleaning reagent.

6.2.3 System cleaning

In spite of the daily cleaning procedures with cleaning solution the valves, tubes, glass parts and several other parts will be soiled.

Therefore the system should be regularly checked and soiled parts should be cleaned or replaced.

The fluid system must always be cleaned with a proper cleaning solution.

In case the photometer unit should give not-reproducible results or show blank values that are too high or unstable, the photometer unit must be cleaned with special cleaning solution.

Attention !

Never rinse Cellcounter with other fluids such as concentrated bleaching agents.

Notice:

Before starting the next measurement the system has to be rinsed well with CELLOTON.

6.2.4 The RBC/WBC-Valve

The cap of the RBC/WBC-valve can be opened by moving the red lever upwards until it is horizontal. A slight turn to the left will open the bayonet lock so that the valve cap can be removed.

The rotary valve can now be taken from the socket. It should be cleaned with alcohol and distilled water (aqua-dest) and all salt crystals removed.

For an long life time you can use silicon (paste). use it only a film, so that the holes will be not blocked.

Notice:

Regular cleaning will increase the life expectation of the valve considerably !

6.2.5 Cleaning of the Diluting and Measuring Chambers

The system has one chamber to receive the blood sample, one mixing chamber and two measuring chambers that are all made of Plexiglas.

It is unavoidable that in usage over a certain period of time deposits and pollution occur. Therefore why the chambers should be cleaned about once a week. For cleaning use a soapy cleaner and afterwards rinse with distilled water.

Attention !

Never use alcohol for cleaning !

!! Alcohol destroys Plexiglas !!

6.2.6 The Valve

Check tubes and rubber on valves for correct setting, when is necessary the have be replaced.

Only use the correct size and length, otherwise the system will not work correctly.

6.2.7 Reagent- and Lysing Syringes

The isotonic- and lyser-syringes can only checked by removing the main cover.

Check it only if is necessary.

If the syringes are leaking they have to be replaced and adjusted by a technician.

After the daily working routine, the whole system should be cleaned by activating "F4" - button **TAKING OUT OF OPERATION** before switching off.

Cleaning solution is drawn from the cleaning container, the whole system is cleaned and refilled, so that awkward soiling is completely avoided.

See that there is sufficient solution in the measuring chambers, so that the aperture of the capillary is always filled with **CELLOCLEAN^E** and protein deposits can be dissolved.

Clean the sample-taker with alcohol so that protein deposits can be dissolved.

Attention !

Avoid that measuring solution remains in the system for a longer period as cells and proteins will be deposited on the walls of the system.

These deposits will cause a pollution of the capillaries, particularly the WBC-measuring-channel and HGB-cuvette.

This pollution can cause not-reproducible measuring results.

Notice:

If you do not use the systems for a short period of time do not take it out of operation.

You should then activate the STANDBY- Mode. Thus all measuring solution inside the system is replaced by isotonic solution.

Also notice, that by activating the STANDBY-Mode the system is not really brought into a different operation mode.

This means that even over a longer interruption of the working routine the system is permanently ready to measure the next sample without any further procedures to put it into operation.

6.3 LONG PERIOD USAGE BREAK

6.3.1 Taking the System out of Operation for a Week.

Firsts clean the system as usual with cleaning solution by activating the **F4-key TAKING OUT OF OPERATION.**

Empty the waste-bottle and fill the supply bottle with aqua-dest.

Fill the instrument by activating the **F3-key TAKING INTO OPERATION.**

Tube system of the lysing reagent supply must be rinsed with aqua-dest by activating the menu point **FILL LYSER.**

Clean the **WBC-valve.**

Clean the **RBC-valve.**

Clean the capillaries with aqua-dest and dry them.

The procedure is now finished and the instrument can be switched off.

If, however, you should want to take the instrument out of operation for even a longer time you should proceed as described in the next point.

6.3.2 Starting the Instrument after a longer Break

When the instrument is taken back into operation after a longer time, the capillaries must be reinstalled and the supply bottles filled, respectively connected. Check all parts for correct connection, particularly the tube-valves.

Attention !

Do not confuse the tubes because the safety-tube will otherwise be pressed off from its socket.

The tubes are correctly connected when the tube that leads to the sample tube is connected on the front side.

Then, you can switch on the instrument and activate **F3-key TAKING INTO OPERATION.**

7 ERROR DESCRIPTIONS

7.1 WHAT TO DO WHEN?

Situation	Possible Reason	Solution
instrument does not work	loose wire or plug and mains plug	check wire and plug of instrument
no display	mains switch off or fuse defective	turn on mains switch, check fuse if nec. replace (pay attention to correct value!) inform service
instrument out of action, no display	electrical defect	inform service
	fuse on power board defective	replace fuse (pay attention to correct value!)
	wires loose at PC-board or aggregate	check correct placement of wire and connect to correct plug if nec.
	loose mechanical parts or aggregate motor defective	inform service

Situation	Possible Reason	Solution
instrument works but turns off after a short time	no vacuum	check measuring system for leaks
	aperture-tube placed incorrectly	check placement of aperture-tube
	aperture-tube blocked	clean aperture-tube, if nec. replace with clean aperture-tube
no filling cycle	electronic defect	inform service
	supply bottle empty tube not deep enough in the supply bottle	fill bottle, sink tube to the bottom of the bottle
system ask always for FILL	mechanical defect	inform service
	tube not deep enough in the supply bottle	sink tube to the bottom of the bottle
		just activated in supply solution
blank values too high	aperture-tube leaks	check aperture-tube for correct placement
	mechanical defect	inform service
	aperture-tube blocked or unclean	replace or clean aperture-tube
blank values too high	aperture-tube or seal broken	check seal, replace if nec., check aperture-tube
	solution soiled diluter soiled	replace solution clean diluter
	bubbles in the solution	repeat measurement try new diluent
	electronic defect	inform service

Situation	Possible Reason	Solution
measuring value too high	blood sample defective or wrong sample volume	check blood extraction system (blood tubes) check diluter, carry out counter control if necessary
	measuring cup soiled	check cup for cleanliness (blank value)
	wrong sample too little lyser	check RBC valve, use more lyser
	lysing time too short	wait for complete lysis lyser empty lysing reagent wrong or defective replace lysing-reagent
measuring value too low	electrical or mechanical defect	inform service
	blood sample defective or wrong measuring volume wrong dilution ratio	check blood extraction system (blood tubes), check diluter, control with capillary-tube, check solution
	Lysing reagent too strong	change lysing reagent
	electrical defect	inform service

Situation	Possible Reason	Solution
instrument does not measure	measuring system not filled aperture-tube blocked	fill system over filling cycle replace or clean aperture-tube
	measuring optic soiled	clean measuring tube
	electronics defective	inform service
instrument shows function break on display	upper light barrier defective or glass tubes soiled	clean glass tube clean system
	incorrect placement of aperture-tube	place aperture-tube correctly
	electronic or mechanical defect	inform service
HGB shows only "00"	electrical or mechanical defect	inform service
HGB-Zero display not-reproducible	WBC-chamber not in the correct position measuring heat not clean	check WBC-chamber for correct setting, suction sonde, check and clean it if is necessary
	defective measuring head	inform service
HGB-values too low	incorrectly calibrated wrong sample	change setting prepare new sample check Diluter and tube on valve
	used solution defective	use new solution
	electronic defect	inform service

Situation	Possible Reason	Solution
HGB-values too high	dilution concentration incorrect	prepare new sample
	incorrectly calibrated	change setting
	lysing reagent defective	replace lysing reagent
	electronics defective	inform service
HGB-solution unstable	system not airtight	check air tightness of the system
	lysing reagent defective	check lysing reagent
	spreading between samples	mechanism does not work properly
	defective valve or tube electronic defect	inform service
	electronic defect	inform service

7.2 PROBLEMS WITH VALVES AND TUBES

Situation	Possible Reason	Solution
system has no vacuum	Bottles not tight	check tubes and Bottles
no or not enough Lyser	Lyser tube blocked	check Lyser tube change tube if is necessary
	valve defective, electrical defect	inform service
no mixing bubbles in the WBC-chamber	no pressure, tube blocked	check mixing tube on WBC-chamber and valve (70), change or clean tube if is necessary
	pump defective, electrical defect	inform service
no cleaning of sample taker drops at sample cleaner	tube blocked	check cleaning tube
	no vacuum	check mixing tube and valve (71), change or clean tube if is necessary
	valve defective, electrical defect	inform service
no change in the HGB value or no solution in the WBC-chamber	tube blocked , no vacuum	check Valve (73/82), change tube if is necessary
	valve defective, electrical defect	inform service

Situation	Possible Reason	Solution
no RBC-chamber solution	tube blocked	check tube on Valve (74, 84), change tube if is necessary
	valve defective, electrical defect	inform service
no cleaning solution on sample taker	tube blocked	check tube on Valve (71), change tube if is necessary
	valve defective, electrical defect	inform service
mixing chambers overflow	no pressure,	check mixing chamber
	tube not tight	check tube connectors
	tube on valves blocked	check tube on Valve (78/79), change tube if
	tube on valve blocked	check tube on Valve (80/81), change tube if is necessary is necessary
	valve defective, pressure pump defective electrical defect	inform service
no isotonic- or clean solution	tube blocked check tube	check tube change tube if is necessary
	valve defective, pressure pump defective electrical defect	inform service

Situation	Possible Reason	Solution
no cleaning solution in the mixing chamber	no vacuum, tube not tight	check mixing chamber check tubes connectors
	tube blocked	check tube on Valve (69/72/76), change tube if is necessary
	valve defective, electrical defect	inform service
no solution aspirating from sample chamber	no vacuum	check tube on valve(73/74), change tube if is necessary
no mixing bubbles in the WBC-chamber	no pressure, tube blocked	check mixing tube on WBC- chamber and tube on valve (70), change or clean tube if is necessary
	pump defective, electrical defect	inform service

Situation	Possible Reason	Solution
no or not enough solution in the WBC-measuring-chamber	no pressure, tube not tight	check mixing check tube connectors
	tube on valve(73) blocked	check tube on Valve (73/79), change tube if
	valve defective, pressure pump defective electrical defect	inform service
RBC-chamber not or not complete empty if sample changed	tube on valve(79) blocked	check tube on Valve (79), change tube if is necessary
	valve defective, electrical defect	inform service
WBC-chamber not or not complete empty if sample changed	tube on valve(79) blocked	check tube on Valve (79), change tube if is necessary
	valve defective, electrical defect	inform service
no Cap.-sample aspiration	micro switch blocked	check micro switch on Cap.-sample taker
	tube on valve(77) or tube on Valve (77), blocked	check tube tube on valve(69, 77), change tube if is necessary
	valve defective, electrical defect	inform service

INDEX

1	INTRODUCTION	1
1.1	GENERAL	2
1.2	NORMAL VALUES FOR HUMAN	3
1.3	NORMAL VALUES FOR ANIMAL	4
2	FUNCTIONAL UNITS	5
2.1	PARTS OF EQUIPMENT	5
2.1.1	<i>Diagram of the Equipment</i>	8
2.1.2	<i>Diagram of the Equipment</i>	9
2.1.3	<i>Diagram of the Equipment</i>	10
2.1.4	<i>Diagram of the Equipment</i>	11
2.1.5	<i>Diagram of the Equipment</i>	12
2.2	UNPACKING THE INSTRUMENT	13
2.2.1	<i>Further Information</i>	15
2.2.2	<i>Fitting of the Capillary</i>	16
2.3	WHAT YOU MUST KNOW IN ANY CASE	17
2.3.1	<i>Important Advice</i>	18
2.4	THE LCD - DISPLAY	19
2.4.1	<i>The Standard or Measuring Menu</i>	20
2.4.2	<i>The Graphic Menu</i>	21
2.5	THE FUNCTIONAL KEYS	22
2.5.1	<i>The MODE-key</i>	22
2.5.2	<i>The CURVE-key</i>	22
2.5.3	<i>The ENTER-key</i>	22
2.5.4	<i>The CURSOR-Keys</i>	22
2.5.5	<i>The E-PRINT-key</i>	22
2.5.6	<i>The START-key</i>	23
2.5.7	<i>The STOP-key</i>	23
2.5.8	<i>The NUMBER-keys</i>	23
2.5.9	<i>F1-Taste</i>	23
2.5.10	<i>F2-Taste</i>	23
2.5.11	<i>F3-Taste</i>	23
2.5.12	<i>F4-Taste</i>	23
3	WORKING WITH THE INSTRUMENT	24
3.1	ENTERING DATE, SAMPLE AND ID-NUMBER	24
3.2	SYSTEM HANDLING	24
3.2.1	<i>The Blank Values</i>	25
3.2.2	<i>The Dilution Station</i>	26
3.2.3	<i>The Sample Sequence</i>	26
3.3	DOCUMENTATION OF MEASUREMENT RESULTS	27
3.3.1	<i>The Graphic Print-out</i>	27
3.3.2	<i>The Ticket Print-out</i>	28

4	ROOTMENU	29
4.1	SELECTION OF SYSTEM FEATURES.....	29
4.1.1	Select Parameters.....	30
4.1.2	PRP Blood.....	30
4.1.3	RBC, THR/PLT, WBC, HGB.....	30
4.1.4	Cap Pressure	31
4.1.5	Fill.....	31
4.1.6	Clean.....	32
4.1.7	Calibration of Standard Values (whole-blood-mode).....	32
4.1.8	Calibration of Standard Values.....	33
4.1.9	Calibration of Standard Values (capillary-blood-mode).....	34
4.1.10	Erase mode	34
4.1.11	Service.....	35
4.1.12	Options	36
4.1.13	Standby-Mode	37
4.1.14	Auto-Clean-Mode.....	38
4.1.15	The Blood-Saving-Mode.....	39
4.1.16	The Auto-Diff-Mode	40
4.1.17	Animal Select.....	41
4.1.18	Capillary replacement	41
4.1.19	DATABASE FEATURES.....	42
4.1.20	Display Database.....	43
4.1.21	Unselect a Sample.....	44
4.1.22	Result is marked with "L", "M", "R" or "?".....	45
4.1.23	SAVING INTO DATABASE.....	45
4.1.24	Erase Database.....	46
4.1.25	Setting Normal Range Value	47
4.1.26	Select Parameters	48
4.1.27	PRP Blood	48
4.1.28	RBC, THR/PLT, WBC, HGB	48
4.2	DILUTER FUNCTIONS.....	49
4.2.1	Filling the Diluter with lysing Reagent.....	49
4.2.2	Filling the Diluter with Celloton	49
4.2.3	Taking into Operation	50
4.2.4	Taking out of Operation.....	50
4.2.5	Lysing Time.....	50
4.2.6	Capillary Blood function.....	51
4.2.7	Dispenser function.....	51
4.3	SYSTEM FUNCTION.....	52
4.3.1	Filling.....	52
4.3.2	Cleaning.....	52
4.4	CALIBRATION	53

4.5	SERVICE.....	54
4.5.1	Calibration HGB.....	54
4.5.2	Factors.....	54
4.5.3	WBC-Settings.....	54
4.5.4	Service Settings.....	55
4.5.5	Lyser Times.....	55
4.5.6	WBC Disc Settings.....	55
4.5.7	Setting Time and Date.....	55
4.5.8	Diluter Info.....	56
4.5.9	Reset Diluter.....	56
4.6	SYSTEM OPTIONS.....	57
4.6.1	Automatic Print-out.....	57
4.6.2	Parallel port Print-out.....	57
4.6.2.1	Graphic Print-out.....	57
4.6.2.2	Ticket Print-out.....	57
4.6.3	RS 232 (no function - switch to off-).....	58
4.6.3.1	Printer Download (no function).....	58
4.6.3.2	Computer Download (no function).....	58
4.6.4	Baud.....	58
4.6.5	SI - Units.....	58
4.6.6	HGB - Units.....	58
4.6.7	Printer Paper-size.....	59
4.6.8	Printer Emulation.....	59
4.6.8.1	IBM Mode.....	59
4.6.8.2	EPSON Mode.....	59
4.6.8.3	THERM Mode.....	59
4.6.9	Auto Standby Mode.....	59
4.6.10	Auto Cleaning Mode.....	59
4.6.11	Blood saving mode.....	60
4.6.12	Three-Part-Diff-Mode.....	60
4.7	WHAT TO DO WHEN THE WBC-SAMPLE-NEEDLE IS BLOCKED?.....	61
4.8	WHAT TO DO WHEN THE RBC- SAMPLE-TUBE IS BLOCKED?.....	62
4.9	WHAT TO DO IF THE WBC-CAPILLARY IS BLOCKED ?.....	64
4.10	WHAT TO DO IF THE RBC-CAPILLARY IS BLOCKED ?.....	65
5	MEASURING WITH THE SYSTEM.....	66
5.1.1	Required Materials.....	66
5.2	PREPARATION OF THE SAMPLE.....	67
5.2.1	Primary-Dilution - WBC (LEUKOCYTES).....	67
5.2.2	Secondary-Dilution - RBC (Erythrocytes).....	67
5.2.3	Capillary Blood Dilution.....	67
5.3	COUNTING OF PLATELETS WITH THR/PLT-ANALYSER.....	68
5.3.1	Determination of Platelets from Whole Blood.....	68
5.3.2	Measuring Range with THR/PLT-Analyzer.....	69
5.3.3	Determination of Blank Values.....	69
5.4	THE DISPLAY OF THE PLATELET DISTRIBUTION.....	70
5.4.1	The standardized Distribution Curve.....	70
5.4.2	The not-standardized Distribution Curve.....	71

5.5	ERROR INDICATIONS WITH THR/PLT-ANALYSER.....	72
5.5.1	<i>Results marked with "L" = LCDW.....</i>	72
5.5.1.1	Normal or extremely high values that are marked with "L" or "I" ...	73
5.5.1.2	Low value marked with "L" = LCDW.....	73
5.5.2	<i>Results marked with "R" = RCDW.....</i>	74
5.5.3	<i>Results marked with "M" = MPV-Alarm.....</i>	75
5.6	RECOGNIZING ERRORS THROUGH THE HISTOGRAM	76
5.6.1	<i>System Error - LCDW.....</i>	76
5.6.2	<i>System Error - RCDW.....</i>	77
5.6.3	<i>System Error - " ? " or "00".....</i>	78
5.7	THE DISPLAY OF THE RBC-DISTRIBUTION.....	79
5.8	THE DISPLAY OF THE WBC-DISTRIBUTION.....	80
5.8.1	<i>Setting WBC - Discriminator.....</i>	81
5.9	PLATELETS BY PRP-DEXTRAN-METHOD.....	82
5.9.1	<i>In General</i>	82
5.9.2	<i>Process-Description</i>	82
5.9.3	<i>Required additional Materials.....</i>	82
5.9.4	<i>Preparation of Samples.....</i>	83
5.9.5	<i>Handling of the Instrument.....</i>	84
5.10	REQUIRED MATERIALS AND REAGENTS.....	85
5.11	WORKING WITH VENOUS- AND CAPILLARY-BLOOD	86
5.11.1	<i>Extraction of Samples.....</i>	86
5.11.2	<i>Venous Extraction (EDTA-Blood)</i>	86
5.11.3	<i>Capillary-Blood</i>	87
5.12	DILUTION RATIOS.....	88
5.12.1	<i>Stability of the samples.....</i>	88
5.12.2	<i>Dilution-steps.....</i>	89
5.12.3	<i>Errors which often occurs.....</i>	90
6	MAINTENANCE.....	91
6.1	DAILY CONTROLS.....	91
6.1.1	<i>The Capillaries</i>	91
6.1.2	<i>The HGB/WBC-Chamber.....</i>	91
6.1.3	<i>Error Reports.....</i>	92
6.2	WEEKLY MAINTENANCE	93
6.2.1	<i>Aperture-tube</i>	93
6.2.2	<i>Measuring and Volume Unit.....</i>	94
6.2.3	<i>System cleaning.....</i>	94
6.2.4	<i>The RBC/WBC-Valve.....</i>	95
6.2.5	<i>Cleaning of the Diluting and Measuring Chambers.....</i>	95
6.2.6	<i>The Valve.....</i>	95
6.2.7	<i>Reagent- and Lysing Syringes</i>	96
6.3	LONG PERIOD USAGE BREAK	97
6.3.1	<i>Taking the System out of Operation for a Week.....</i>	97
6.3.2	<i>Starting the Instrument after a longer Break.....</i>	97
7	ERROR DESCRIPTIONS.....	98
7.1	WHAT TO DO WHEN?.....	98
7.2	PROBLEMS WITH VALVES AND TUBES.....	103